

# The History of Stokes' Theorem

*Let us give credit where credit is due:  
Theorems of Green, Gauss and Stokes  
appeared unheralded in earlier work.*

**VICTOR J. KATZ**

*University of the District of Columbia  
Washington, D.C. 20005*

Most current American textbooks in advanced calculus devote several sections to the theorems of Green, Gauss, and Stokes. Unfortunately, the theorems referred to were not original to these men. It is the purpose of this paper to present a detailed history of these results from their origins to their generalization and unification into what is today called the generalized Stokes' theorem.

## Origins of the theorems

The three theorems in question each relate a  $k$ -dimensional integral to a  $k-1$ -dimensional integral; since the proof of each depends on the fundamental theorem of calculus, it is clear that their origins can be traced back to the late 17th century. Toward the end of the 18th century, both Lagrange and Laplace actually used the fundamental theorem and iteration to reduce  $k$ -dimensional integrals to those of one dimension less. However, the theorems as we know them today did not appear explicitly until the 19th century.

The first of these theorems to be stated and proved in essentially its present form was the one known today as Gauss' theorem or the divergence theorem. In three special cases it occurs in an 1813 paper of Gauss [8]. Gauss considers a surface (superficies) in space bounding a solid body (corpus). He denotes by  $PQ$  the exterior normal vector to the surface at a point  $P$  in an infinitesimal element of surface  $ds$  and by  $QX, QY, QZ$  the angles this vector makes with the positive  $x$ -axis,  $y$ -axis, and  $z$ -axis respectively. Gauss then denotes by  $d\Sigma$  an infinitesimal element of the  $y-z$  plane and erects a cylinder above it, this cylinder intersecting the surface in an even number of infinitesimal surface elements  $ds_1, ds_2, \dots, ds_{2n}$ . For each  $j$ ,  $d\Sigma = \pm ds_j \cos QX_j$  where the positive sign is used when the angle is acute, the negative when the angle is obtuse. Since if the cylinder enters the surface where  $QX$  is obtuse, it will exit where  $QX$  is acute (see FIGURE 1), Gauss obtains  $d\Sigma = -ds_1 \cos QX_1 = ds_2 \cos QX_2 = \dots$  and concludes by summation that "The integral  $\int ds \cos QX$  extended to the entire surface of the body is 0."

He notes further that if  $T, U, V$  are rational functions of only  $y, z$ , only  $x, z$ , and only  $x, y$  respectively, then " $\int (T \cos QX + U \cos QY + V \cos QZ) ds = 0$ ." Gauss then approximates the volume of the body by taking cylinders of length  $x$  and cross sectional area  $d\Sigma$  and concludes in a similar way his next theorem: "The entire volume of the body is expressed by the integral  $\int ds x (\cos QX)$  extended to the entire surface." We will see below how these results are special cases of the divergence theorem.

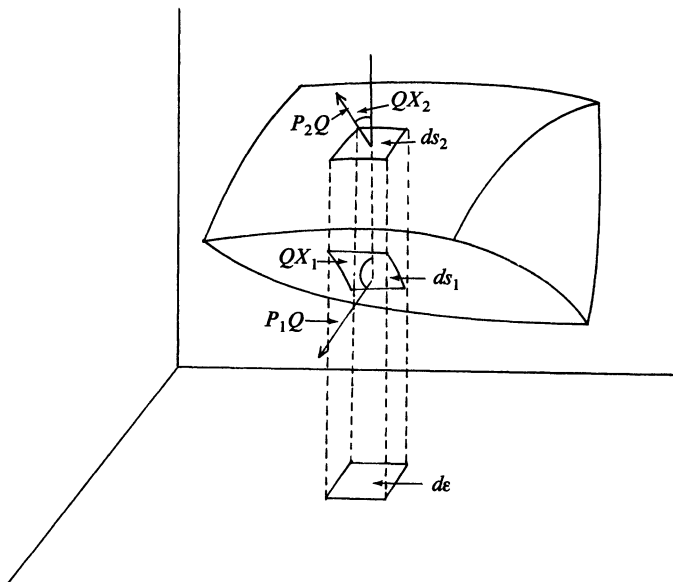

FIGURE 1

In 1833 and 1839 Gauss published other special cases of this theorem, but by that time the general theorem had already been stated and proved by Michael Ostrogradsky. This Russian mathematician, who was in Paris in the late 1820's, presented a paper [15] to the Paris Academy of Sciences on February 13, 1826, entitled "Proof of a theorem in Integral Calculus." In this paper Ostrogradsky introduces a surface with element of surface area  $\epsilon$  bounding a solid with element of volume  $\omega$ . He denotes by  $\alpha, \beta, \gamma$  the same angles which Gauss called  $QX, QY, QZ$ , and by  $p, q, r$  three differentiable functions of  $x, y, z$ . He states the divergence theorem in the form:

$$\int \left( a \frac{\partial p}{\partial x} + b \frac{\partial q}{\partial y} + c \frac{\partial r}{\partial z} \right) \omega = \int (ap \cos \alpha + bq \cos \beta + cr \cos \gamma) \epsilon$$

where  $a, b, c$  are constants and where the left hand integral is taken over a solid, the right hand integral over the boundary surface.

We note that Gauss' results are all special cases of Ostrogradsky's theorem. In each case  $a = b = c = 1$ ; Gauss' first result has  $p = 1, q = r = 0$ ; his second has

$$\frac{\partial p}{\partial x} = \frac{\partial q}{\partial y} = \frac{\partial r}{\partial z} = 0;$$

and his third has  $p = x, q = r = 0$ . We also will see that Gauss' proof is a special case of that of Ostrogradsky.

Ostrogradsky proves his result by first considering  $\frac{\partial p}{\partial x} \omega$ . He integrates this over a "narrow cylinder" going through the solid in the  $x$ -direction with cross-sectional area  $\bar{\omega}$ , using the fundamental theorem of calculus to express this integral as

$$\int \frac{\partial p}{\partial x} \omega = \int (p_1 - p_0) \bar{\omega},$$

where  $p_0$  and  $p_1$  are the values of  $p$  on the pieces of surface where the cylinder intersects the solid. Since  $\bar{\omega} = \epsilon_1 \cos \alpha_1$  on one section of surface and  $\bar{\omega} = -\epsilon_0 \cos \alpha_0$  on the other ( $\alpha_1$  and  $\alpha_0$  being the appropriate angles made by the normal,  $\epsilon_1$  and  $\epsilon_0$  being the respective surface elements) we get

$$\int \frac{\partial p}{\partial x} \omega = \int p_1 \epsilon_1 \cos \alpha_1 + \int p_0 \epsilon_0 \cos \alpha_0 = \int p \cos \alpha \epsilon$$

where the left integral is over the cylinder and the right ones over the two pieces of surface (FIGURE 2). Adding up the integrals over all such cylinders gives one third of the final result, the other two thirds being done similarly. We note that this proof can easily be modified to suit modern standards, and is in fact used today, e.g., in Taylor and Mann [24].

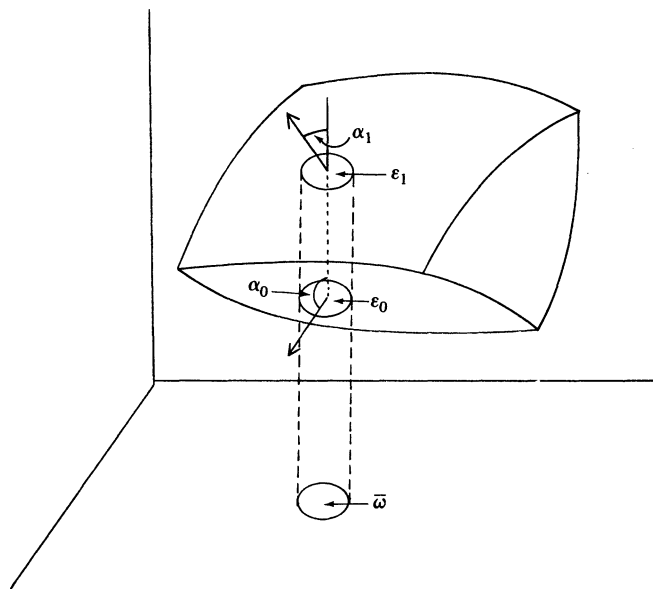

FIGURE 2

Though the above proof applies to arbitrary differentiable functions  $p, q, r$ , we will note for future reference that Ostrogradsky uses the result only in the special case where

$$p = v \frac{\partial u}{\partial x} - u \frac{\partial v}{\partial x}, \quad q = v \frac{\partial u}{\partial y} - u \frac{\partial v}{\partial y}, \quad r = v \frac{\partial u}{\partial z} - u \frac{\partial v}{\partial z},$$

with  $u$  and  $v$  also being differentiable functions of three variables.

Ostrogradsky presented this theorem again in a paper in Paris on August 6, 1827, and finally in St. Petersburg on November 5, 1828. The latter presentation was the only one published by Ostrogradsky, appearing in 1831 in [16]. The two earlier presentations have survived only in manuscript form, though they have been published in Russian translation.

In the meantime, the theorem and related ones appeared in publications of three other mathematicians. Simeon Denis Poisson, in a paper presented in Paris on April 14, 1828, (published in 1829) stated and proved an identical result [19]. According to Yushkevich in [28], Poisson had refereed Ostrogradsky's 1827 paper and therefore presumably learned of the result. Poisson neither claimed it as original nor cited Ostrogradsky, but it must be realized that references were not made then with the frequency that they are today.

Another French mathematician, Frederic Sarrus, published a similar result in 1828 in [21], but his notation and ideas are not nearly so clear as those of Ostrogradsky and Poisson. Finally, George Green, an English mathematician, in a private publication of the same year [9], stated and proved the following:

$$\int u \Delta v \, dx \, dy \, dz + \int u \frac{dv}{dw} \, d\sigma = \int v \Delta u \, dx \, dy \, dz + \int v \frac{du}{dw} \, d\sigma$$

where  $u, v$  are functions of three variables in a solid body “of any form whatever,”  $\Delta$  is the symbol for the Laplacian, and  $d/dw$  means the normal derivative; the first integrals on each side are taken over the solid and the second over the boundary surface. Green proved his theorem using the same basic ideas as did Ostrogradsky. In addition, if we use again the special case where

$$p = v \frac{\partial u}{\partial x} - u \frac{\partial v}{\partial x}, \quad q = v \frac{\partial u}{\partial y} - u \frac{\partial v}{\partial y}, \quad r = v \frac{\partial u}{\partial z} - u \frac{\partial v}{\partial z},$$

we can conclude by a short calculation that the two theorems are equivalent. Nevertheless, Green did not so conclude; he was interested in the theorem in the form in which he gave it. It would thus be difficult to attribute the divergence theorem to him.

All of the mathematicians who stated and proved versions of this theorem were interested in it for specific physical reasons. Gauss was interested in the theory of magnetic attraction, Ostrogradsky in the theory of heat, Green in electricity and magnetism, Poisson in elastic bodies, and Sarrus in floating bodies. In nearly all cases, the theorems involved occurred in the middle of long papers and were only thought of as tools toward some physical end. In fact, for both Green and Ostrogradsky the functions  $u$  and  $v$  mentioned above were often solutions of Laplace-type equations and were used in boundary value problems.

The theorem generally known as Green’s theorem is a two-dimensional result which was also not considered by Green. Of course, one can derive this theorem from Green’s version by reducing it to two dimensions and making a brief calculation. But there is no evidence that Green himself ever did this.

On the other hand, since Green’s theorem is crucial in the elementary theory of complex variables, it is not surprising that it first occurs, without proof, in an 1846 note of Augustin Cauchy [5], in which he proceeds to use it to prove “Cauchy’s theorem” on the integral of a complex function around a closed curve. Cauchy presents the result in the form:

$$\int \left( p \frac{dx}{ds} + q \frac{dy}{ds} \right) ds = \pm \iint \left( \frac{\partial p}{\partial y} - \frac{\partial q}{\partial x} \right) dx dy$$

where  $p$  and  $q$  are functions of  $x$  and  $y$ , and where the sign of the second integral depends on the orientation of the curve which bounds the region over which the integral is taken. Cauchy promised a proof in his private journal *Exercices d’analyse et de physique mathématique*, but he apparently never published one.

Five years later, Bernhard Riemann presented the same theorem in his inaugural dissertation [20], this time with proof and in several related versions; again he uses the theorem in connection with the theory of complex variables. Riemann’s proof is quite similar to the proof commonly in use today; essentially he uses the fundamental theorem to integrate  $\partial q/\partial x$  along lines parallel to the  $x$ -axis, getting values of  $q$  where the lines cross the boundary of the region; then he integrates with respect to  $y$  to get

$$\int \left[ \int \frac{\partial q}{\partial x} dx \right] dy = - \int q dy = - \int q \frac{dy}{ds} ds.$$

The other half of the formula is proved similarly.

The final theorem of our triad, Stokes’ theorem, first appeared in print in 1854. George Stokes had for several years been setting the Smith’s Prize Exam at Cambridge, and in the February, 1854, examination, question #8 is the following [22] (see FIGURE 3):

If  $X, Y, Z$  be functions of the rectangular coordinates  $x, y, z$ ,  $dS$  an element of any limited surface,  $l, m, n$  the cosines of the inclinations of the normal at  $dS$  to the axes,  $ds$  an element of the boundary line, shew that

$$\iint \left\{ l \left( \frac{\partial Z}{\partial y} - \frac{\partial Y}{\partial z} \right) + m \left( \frac{\partial X}{\partial z} - \frac{\partial Z}{\partial x} \right) + n \left( \frac{\partial Y}{\partial x} - \frac{\partial X}{\partial y} \right) \right\} dS = \int \left( X \frac{dx}{ds} + Y \frac{dy}{ds} + Z \frac{dz}{ds} \right) ds$$

... the single integral being taken all around the perimeter of the surface.

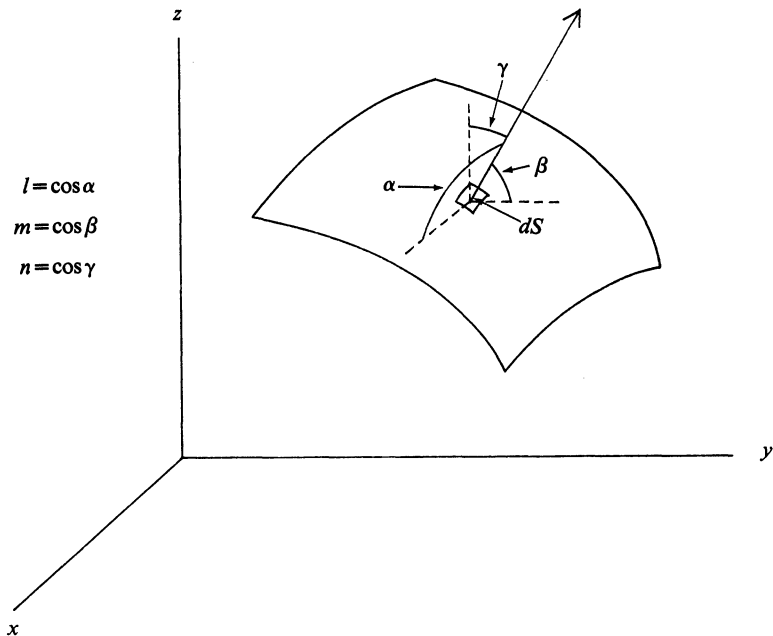

FIGURE 3

It does not seem to be known if any of the students proved the theorem. However, the theorem had already appeared in a letter of William Thomson (Lord Kelvin) to Stokes on July 2, 1850, and the left hand expression of the theorem had appeared in two earlier works of Stokes. The first published proof of the theorem seems to have been in a monograph of Hermann Hankel in 1861 [10]. Hankel gives no credit for the theorem, only a reference to Riemann with regard to Green's theorem, which theorem he calls well-known and makes use of in his own proof of Stokes' result.

In his proof Hankel considers the integral  $\int X dx + Y dy + Z dz$  over a curve bounding a surface given explicitly by  $z = z(x, y)$ . Then

$$dz = \frac{\partial z}{\partial x} dx + \frac{\partial z}{\partial y} dy;$$

so the given integral becomes

$$\int \left( X + \frac{\partial z}{\partial x} Z \right) dx + \left( Y + \frac{\partial z}{\partial y} Z \right) dy.$$

By Green's theorem, this integral in turn becomes

$$\iint \left\{ \frac{\partial \left( X + \frac{\partial z}{\partial x} Z \right)}{\partial y} - \frac{\partial \left( Y + \frac{\partial z}{\partial y} Z \right)}{\partial x} \right\} dx dy.$$

An explicit evaluation of the derivatives then leads to the result:

$$\int (X dx + Y dy + Z dz) = \iint \left\{ \left( \frac{\partial X}{\partial y} - \frac{\partial Y}{\partial x} \right) + \left( \frac{\partial Z}{\partial y} - \frac{\partial Y}{\partial z} \right) \frac{\partial z}{\partial x} + \left( \frac{\partial X}{\partial z} - \frac{\partial Z}{\partial x} \right) \frac{\partial z}{\partial y} \right\} dx dy.$$

Since a normal vector to the surface is given by  $(-\partial z/\partial x, -\partial z/\partial y, 1)$  and since the components of the unit normal vector are the cosines of the angles which that vector makes with the coordinate axes, it follows that  $\partial z/\partial x = -1/n$ ,  $\partial z/\partial y = -m/n$ , and  $dS = dx dy/n$ . Hence by substitution, Hankel obtains the desired result.

Of course, this proof requires the surface to be given explicitly as  $z = z(x, y)$ . A somewhat different proof, without that requirement, is sketched in Thomson and Tait's *Treatise on Natural Philosophy* (1867) without reference [25]. In 1871 Clerk Maxwell wrote to Stokes asking about the history of the theorem [12]. Evidently Stokes answered him, since in Maxwell's 1873 *Treatise on Electricity and Magnetism* there appears the theorem with the reference to the Smith's Prize Exam [13]. Maxwell also states and proves the divergence theorem.

### Vector forms of the theorems

All three theorems first appeared, as we have seen, in their coordinate forms. But since the theory of quaternions was being developed in the mid-nineteenth century by Hamilton and later by Tait, it was to be expected that the theorems would be translated into their quaternion forms. First we must note that Hamilton's product of two quaternions

$$\mathbf{p} = x_0 + x_1\mathbf{i} + x_2\mathbf{j} + x_3\mathbf{k} \text{ and } \mathbf{q} = y_0 + y_1\mathbf{i} + y_2\mathbf{j} + y_3\mathbf{k}$$

may be written as

$$\mathbf{pq} = (x_0y_0 - x_1y_1 - x_2y_2 - x_3y_3) + (x_2y_3 - y_2x_3)\mathbf{i} + (x_3y_1 - y_3x_1)\mathbf{j} + (x_1y_2 - x_2y_1)\mathbf{k}.$$

The scalar part is denoted  $S \cdot \mathbf{pq}$  and the vector part  $V \cdot \mathbf{pq}$ . Secondly, applying Hamilton's  $\nabla$ -operator  $\mathbf{i}\partial/\partial x + \mathbf{j}\partial/\partial y + \mathbf{k}\partial/\partial z$  to a vector function  $\boldsymbol{\sigma} = \mathbf{i}X + \mathbf{j}Y + \mathbf{k}Z$  we get a quaternion

$$\nabla \boldsymbol{\sigma} = -\left(\frac{\partial X}{\partial x} + \frac{\partial Y}{\partial y} + \frac{\partial Z}{\partial z}\right) + \mathbf{i}\left(\frac{\partial Z}{\partial y} - \frac{\partial Y}{\partial z}\right) + \mathbf{j}\left(\frac{\partial X}{\partial z} - \frac{\partial Z}{\partial x}\right) + \mathbf{k}\left(\frac{\partial Y}{\partial x} - \frac{\partial X}{\partial y}\right).$$

Again we denote the scalar part by  $S \nabla \boldsymbol{\sigma}$  and the vector part by  $V \nabla \boldsymbol{\sigma}$ .

Tait, then, in an 1870 paper [23] was able to state the divergence theorem in the form

$$\iiint S \cdot \nabla \boldsymbol{\sigma} d\xi = \iint S \cdot \boldsymbol{\sigma} U\nu ds$$

where  $d\xi$  is an element of volume,  $ds$  an element of surface, and  $U\nu$  a unit normal vector to the surface. Furthermore, Stokes' theorem took the form

$$\int S \cdot \boldsymbol{\sigma} d\rho = \iint S \cdot V \nabla \boldsymbol{\sigma} U\nu d\xi$$

where  $d\rho$  is an element of length of the curve bounding the surface.

Maxwell, in his treatise of three years later, repeated Tait's formulas, but also came one step closer to our current terminology. He proposed to call  $S \nabla \boldsymbol{\sigma}$  the *convergence* of  $\boldsymbol{\sigma}$  and  $V \nabla \boldsymbol{\sigma}$  the *curl* of  $\boldsymbol{\sigma}$ . Of course, Maxwell's convergence is the negative of what we call the divergence. Furthermore, we note that when two quaternions  $\mathbf{p}$  and  $\mathbf{q}$  are pure vectors, Hamilton's  $S \cdot \mathbf{pq}$  is precisely the negative of the inner product  $\mathbf{p} \cdot \mathbf{q}$ . (This particular idea was first developed by Gibbs and Heaviside about twenty years later.)

Putting these notions together, we get the modern vector form of the divergence theorem

$$\iiint_M (\text{div } \boldsymbol{\sigma}) dV = \iint_S \boldsymbol{\sigma} \cdot \mathbf{n} dA$$

where  $\boldsymbol{\sigma}$  is a vector field  $X\mathbf{i} + Y\mathbf{j} + Z\mathbf{k}$ ,  $dV$  is an element of volume,  $dA$  is an element of surface area of the surface  $S$  bounding the solid  $M$  and  $\mathbf{n}$  is the unit outward normal to this surface. Stokes' theorem then takes the form

$$\iint_S (\text{curl } \boldsymbol{\sigma}) \cdot \mathbf{n} dA = \int_\Gamma (\boldsymbol{\sigma} \cdot \mathbf{t}) ds$$

where  $ds$  is the element of length of the boundary curve  $\Gamma$  of the surface  $S$  and  $\mathbf{t}$  is the unit tangent vector to  $\Gamma$ . Obviously, a similar result can be given for Green's theorem.

### Generalization and unification

The generalization and unification of our three theorems took place in several stages. First of all, Ostrogradsky himself in an 1836 paper in Crelle [17] generalized his own theorem to the following:

$$\int_V \left( \frac{\partial P}{\partial x} + \frac{\partial Q}{\partial y} + \frac{\partial R}{\partial z} + \dots \right) dx dy dz \dots = \int_S \frac{\left( P \frac{\partial L}{\partial x} + Q \frac{\partial L}{\partial y} + R \frac{\partial L}{\partial z} + \dots \right)}{\sqrt{\left( \frac{\partial L}{\partial x} \right)^2 + \left( \frac{\partial L}{\partial y} \right)^2 + \left( \frac{\partial L}{\partial z} \right)^2 + \dots}} dS.$$

Here Ostrogradsky lets  $L(x,y,z,\dots)$  be “a function of as many quantities as one wants,”  $V$  be the set of values  $x,y,z,\dots$  with  $L(x,y,z,\dots) > 0$  and  $S$  be the set of values with  $L(x,y,z,\dots) = 0$ . In modern terminology, if there are  $n$ -values,  $S$  would be an  $n-1$ -dimensional hypersurface bounding the  $n$ -dimensional volume  $V$ .

Ostrogradsky’s proof here is similar to his first one. He integrates  $\partial P/\partial x$  with respect to  $x$  and after a short manipulation gets

$$\int \frac{\partial P}{\partial x} dx dy dz \dots = \int \frac{P \frac{\partial L}{\partial x}}{\sqrt{\left( \frac{\partial L}{\partial x} \right)^2}} dy dz \dots$$

with, of course a similar expression for every other term. Then, putting  $dS = \sqrt{dy^2 dz^2 \dots + dx^2 dz^2 \dots + dx^2 dy^2 \dots + \dots}$ , he shows that

$$\frac{dy dz \dots}{\sqrt{\left( \frac{\partial L}{\partial x} \right)^2}} = \frac{dx dz \dots}{\sqrt{\left( \frac{\partial L}{\partial y} \right)^2}} = \dots = \frac{dS}{\sqrt{\left( \frac{\partial L}{\partial x} \right)^2 + \left( \frac{\partial L}{\partial y} \right)^2 + \left( \frac{\partial L}{\partial z} \right)^2 + \dots}}$$

and concludes the result by summation.

(To understand how Ostrogradsky gets his expression for  $dS$ , we note that for a parametrized surface in three-space,

$$dS = \Delta du dv = \sqrt{\left( \frac{\partial(y,z)}{\partial(u,v)} \right)^2 + \left( \frac{\partial(z,x)}{\partial(u,v)} \right)^2 + \left( \frac{\partial(x,y)}{\partial(u,v)} \right)^2} du dv$$

and

$$\frac{\partial(y,z)}{\partial(u,v)} du dv = dy dz, \quad \frac{\partial(z,x)}{\partial(u,v)} du dv = dz dx, \quad \frac{\partial(x,y)}{\partial(u,v)} du dv = dx dy.$$

Hence

$$dS = \sqrt{dy^2 dz^2 + dz^2 dx^2 + dx^2 dy^2}.$$

For more details, see [1].)

If we further note that

$$\left( \sqrt{\left( \frac{\partial L}{\partial x} \right)^2 + \left( \frac{\partial L}{\partial y} \right)^2 + \left( \frac{\partial L}{\partial z} \right)^2 + \dots} \right)^{-1} \left( \frac{\partial L}{\partial x}, \frac{\partial L}{\partial y}, \frac{\partial L}{\partial z}, \dots \right)$$

is the unit outward normal  $\mathbf{n}$  to  $S$  and if we let  $\sigma$  denote the vector function  $(P, Q, R, \dots)$ , then Ostrogradsky’s result becomes

$$\int (\text{div } \sigma) dV = \int \sigma \cdot \mathbf{n} dS,$$

a direct generalization of the original divergence theorem.

The first mathematician to include all three theorems under one general result was Vito Volterra in 1889 in [27]. Before quoting the theorem, we need to understand his terminology. An  $r$ -dimensional hyperspace in  $n$ -dimensional space is given parametrically by the  $n$  functions  $x_i = x_i(u_1, u_2, u_3, \dots, u_r)$ ,  $i = 1, \dots, n$ . Volterra considers the  $n$  by  $r$  matrix  $J = (\partial x_i / \partial u_j)$  and denotes by  $\Delta_{i_1, i_2, \dots, i_r}$  the determinant of the  $r$  by  $r$  submatrix of  $J$  consisting of the rows numbered  $i_1, i_2, \dots, i_r$ . Letting

$$\Delta = \left( \sum_{i_1 < \dots < i_r} \Delta_{i_1, i_2, \dots, i_r}^2 \right)^{\frac{1}{2}},$$

he calls  $\Delta du_1 du_2 \dots du_r$  an "element of hyperspace" and  $\alpha_{i_1, \dots, i_r} = (\Delta_{i_1, \dots, i_r} / \Delta)$  a direction cosine of the hyperspace. (The  $\alpha$ 's are, of course, functions of the  $u$ 's.) For the case where  $r=2$  and  $n=3$  we have already calculated  $\Delta$  above in our discussion of Ostrogradsky's theorem. Since the determinants  $\partial(x_i, x_j) / \partial(u_1, u_2)$  are precisely the components of the normal vector to the surface, the  $\alpha_{ij}$  are then the components of the unit normal vector, hence are the cosines of the angles which that vector makes with the appropriate coordinate axes.

We now quote Volterra's theorem, translated from the Italian:

Let  $L_{i_1 i_2 \dots i_r}$  be functions of points in a hyperspace  $S_n$  defined and continuous in all their first derivatives and such that any transposition of indices changes only the sign. Let the forms

$$M_{i_1 i_2 \dots i_{r+1}} = \sum_{s=1}^{r+1} (-1)^{s-1} \frac{\partial L_{i_1 i_2 \dots i_r - i_{s+1} \dots i_{r+1}}}{\partial x_{i_s}}.$$

We denote by  $S_r$  the boundary of a hyperspace  $S_{r+1}$  of  $r+1$  dimensions open and immersed in  $S_n$ ; by  $\alpha_{i_1 i_2 \dots i_{r+1}}$  the direction cosines of  $S_{r+1}$  and by  $\beta_{i_1 i_2 \dots i_r}$  those of  $S_r$ . The extension of the theorem of Stokes consists of the following formula:

$$\int_{S_{r+1}} \sum_i M_{i_1 i_2 \dots i_{r+1}} \alpha_{i_1 i_2 \dots i_{r+1}} dS_{r+1} = \int_{S_r} \sum_i L_{i_1 i_2 \dots i_r} \beta_{i_1 i_2 \dots i_r} dS_r.$$

Let us check the case where  $r=1$  and  $n=3$  to see how this result generalizes Stokes' theorem. In that case we have three functions  $L_1, L_2, L_3$  of points in three-dimensional space. The  $M$  functions are then given as follows:

$$M_{12} = \frac{\partial L_2}{\partial x_1} - \frac{\partial L_1}{\partial x_2}, \quad M_{31} = \frac{\partial L_1}{\partial x_3} - \frac{\partial L_3}{\partial x_1}, \quad M_{23} = \frac{\partial L_3}{\partial x_2} - \frac{\partial L_2}{\partial x_3}.$$

Since  $r=1$ ,  $S_r$  is a curve given by 3 functions  $x_1(u)$ ,  $x_2(u)$ , and  $x_3(u)$ . So

$$\Delta = \sqrt{\left(\frac{dx_1}{du}\right)^2 + \left(\frac{dx_2}{du}\right)^2 + \left(\frac{dx_3}{du}\right)^2}$$

and  $ds = \Delta du$ . Then

$$\beta_i = \frac{dx_i}{\Delta} \quad \text{for } i = 1, 2, 3 \quad \text{and } \beta_i ds = \frac{dx_i}{du} du.$$

The  $\alpha_{12}$ ,  $\alpha_{31}$ , and  $\alpha_{23}$  are the appropriate cosines as mentioned above. Hence the theorem will read:

$$\begin{aligned} \int_{S_2} \left( \frac{\partial L_3}{\partial x_2} - \frac{\partial L_2}{\partial x_3} \right) \alpha_{23} + \left( \frac{\partial L_1}{\partial x_3} - \frac{\partial L_3}{\partial x_1} \right) \alpha_{31} + \left( \frac{\partial L_2}{\partial x_1} - \frac{\partial L_1}{\partial x_2} \right) \alpha_{12} dS_2 \\ = \int_{S_1} \left( L_1 \frac{dx_1}{du} + L_2 \frac{dx_2}{du} + L_3 \frac{dx_3}{du} \right) du, \end{aligned}$$

the result being exactly Stokes' theorem. A similar calculation will show that the case  $r=2, n=3$  will give the divergence theorem, the case  $r=1, n=2$  will give Green's theorem, and the case  $r=n-1$  is precisely Ostrogradsky's own generalization.

We note further that if we replace  $\alpha_{ij}$  by  $(\partial(x_i, x_j)/\partial(u, v))/\Delta$ ,  $dS_2$  by  $\Delta du dv$ , and  $(\partial(x_i, x_j)/\partial(u, v)) du dv$  by  $dx_i dx_j$ , and if we set  $x_1 = x$ ,  $x_2 = y$ ,  $x_3 = z$ , we get another familiar form of Stokes' theorem:

$$\int_{S_2} M_{23} dy dz + M_{31} dz dx + M_{12} dx dy = \int_{S_1} L_1 dx + L_2 dy + L_3 dz.$$

Similarly, the divergence theorem becomes

$$\int_{S_3} L_{23} dy dz + L_{31} dz dx + L_{12} dx dy = \int_{S_2} \left( \frac{\partial L_{23}}{\partial x} + \frac{\partial L_{31}}{\partial y} + \frac{\partial L_{12}}{\partial z} \right) dx dy dz.$$

Although Volterra used his theorem in several papers in his study of differential equations, he did not give a proof of the result; he only said that it "is obtained without difficulty."

If one studies Volterra's work, it becomes clear that it would be quite useful to simplify the notation. This was done by several mathematicians around the turn of the century. Henri Poincaré, in his 1899 work *Les Méthodes Nouvelles de la Mécanique Céleste* [18], states the same generalization as Volterra, but in a much briefer form:

$$\int \sum A d\omega = \int \sum \sum_k \pm \frac{dA}{dx_k} dx_k d\omega.$$

Here the left-hand integral is taken over the  $r-1$ -dimensional boundary of an  $r$ -dimensional variety in  $n$ -space while the right-hand integral is over the entire variety. Hence  $A$  is a function of  $n$  variables and  $d\omega$  is a product of  $r-1$  of the  $dx_i$ 's, the sum being taken over all such distinct products. Poincaré's form of the theorem is more compact than that of Volterra in part because the direction cosines are absorbed into the expressions  $d\omega$ . (See [1] for more details.) Poincaré, like Volterra, in this and other works of the same period, was chiefly interested in integrability conditions of what we now call differential forms; i.e., in when a form  $\omega$  is an exact differential.

The mathematician chiefly responsible for clarifying the idea of a differential form was Elie Cartan. In his fundamental paper of 1899 [2], he first defines an "expression différentielle" as a symbolic expression given by a finite number of sums and products of the  $n$  differentials  $dx_1, dx_2, \dots, dx_n$  and certain coefficient functions of the variables  $x_1, x_2, \dots, x_n$ . A differential expression of the first degree,  $A_1 dx_1 + A_2 dx_2 + \dots + A_n dx_n$ , he calls an "expression de Pfaff."

Cartan states certain rules of calculation with these expressions. In particular, his rule for "evaluating" a differential expression requires that the value of  $A dx_{m_1} dx_{m_2} \dots dx_{m_n}$  be the product of  $A$  with the determinant  $|\partial x_{m_j}/\partial \alpha_i|$  where the  $x$ 's are functions of the parameters  $\alpha$ . The standard rules for determinants then require that if any  $dx_i$  is repeated, the value is 0 and that any permutation of the  $dx_i$ 's requires a sign change if the permutation is odd. For instance, Cartan concludes that  $A dx_1 dx_2 dx_3 = -A dx_2 dx_1 dx_3$ , or just that  $dx_1 dx_2 = -dx_2 dx_1$ .

Cartan further discusses changes of variable; if  $x_1, x_2, \dots, x_n$  are functions of  $y_1, y_2, \dots, y_n$ , then

$$dx_i = \frac{\partial x_i}{\partial y_1} dy_1 + \frac{\partial x_i}{\partial y_2} dy_2 + \dots + \frac{\partial x_i}{\partial y_n} dy_n, \quad i = 1, 2, \dots, n.$$

Then, for instance, in the case  $n=2$ , we get

$$dx_1 dx_2 = \frac{\partial(x_1, x_2)}{\partial(y_1, y_2)} dy_1 dy_2.$$

One might note, on the other hand, that if one assumes a change of variable formula of this type, then one is forced to the general rule  $dx_i dx_j = -dx_j dx_i$ .

Finally, Cartan defines the “derived expression” of a first degree differential expression  $\omega = A_1 dx_1 + A_2 dx_2 + \cdots + A_n dx_n$  to be the second degree expression  $\omega' = dA_1 dx_1 + dA_2 dx_2 + \cdots + dA_n dx_n$ , where, of course,

$$dA_i = \sum_j \frac{\partial A_i}{\partial x_j} dx_j.$$

For the case  $n=3$  one can calculate by using the above rules that if  $\omega = A_1 dx + A_2 dy + A_3 dz$ , then

$$\omega' = \left( \frac{\partial A_3}{\partial y} - \frac{\partial A_2}{\partial z} \right) dy dz + \left( \frac{\partial A_1}{\partial z} - \frac{\partial A_3}{\partial x} \right) dz dx + \left( \frac{\partial A_2}{\partial x} - \frac{\partial A_1}{\partial y} \right) dx dy.$$

Comparing this with the example we gave in discussing Volterra’s work, it is clear that Volterra’s  $M_{23}$ ,  $M_{31}$ , and  $M_{12}$  are precisely the coefficients of Cartan’s  $\omega'$ .

Cartan in [2] did not discuss the relationship of his differential expressions to Stokes’ theorem; nevertheless, by the early years of the twentieth century the generalized Stokes’ theorem in essentially the form given by Poincaré was known and used by many authors, although proofs seem not to have been published.

By 1922, Cartan had extended his work on differential expressions in [3]. It is here that he first uses the current terminology of “exterior differential form” and “exterior derivative.” He works out specifically the derivative of a 1-form (as we did above) and notes that for  $n=3$  Stokes’ theorem states that  $\int_C \omega = \int \int_S \omega'$  where  $C$  is the boundary curve of the surface  $S$ . (This is, of course, exactly Volterra’s result in the same special case.) Then, defining the exterior derivative of any differential form  $\omega = \sum A dx_1 dx_2 \dots dx_n$  to be  $\omega' = \sum dA dx_1 dx_2 \dots dx_n$  (with  $dA$  as above), he works out the derivative of a 2-form  $\Omega$  in the special case  $n=3$  and shows that for a parallelepiped  $P$  with boundary  $S$ ,  $\int \int_S \Omega = \int \int \int_P \Omega'$ . One can easily calculate that this is the divergence theorem, and we must assume that Cartan realized its truth in more general cases. He was, however, not yet ready to state the most general result.

The “ $d$ ” notation for exterior derivative was used in 1902 by Theodore DeDonder in [6], but not again until Erich Kähler reintroduced it in his 1934 book *Einführung in die Theorie der Systeme von Differentialgleichungen* [11]. His notation is slightly different from ours, but in a form closer to ours it was adopted by Cartan for a course he gave in Paris in 1936–37 (published as *Les Systèmes Différentiels Extérieurs et leurs Applications Géométriques* [4] in 1945). Here, after discussing the definitions of the differential form  $\omega$  and its derivative  $d\omega$ , Cartan notes that all of our three theorems (which he attributes to Ostrogradsky, Cauchy-Green, and Stokes, respectively) are special cases of  $\int_C \omega = \int_A d\omega$  where  $C$  is the boundary of  $A$ . To be more specific, Green’s theorem is the special case where  $\omega$  is a 1-form in 2-space; Stokes’ theorem is the special case where  $\omega$  is a 1-form in 3-space; and the divergence theorem is the special case where  $\omega$  is a 2-form in 3-space. Finally, Cartan states that for any  $p+1$ -dimensional domain  $A$  with  $p$ -dimensional boundary  $C$  one could demonstrate the general Stokes’ formula:

$$\int_C \omega = \int_A d\omega$$

(For examples of the use of these theorems, see any advanced calculus text, e.g., [1] or [24]. For more information on differential forms, one can consult [7].)

### Appearance in texts

A final interesting point about these theorems is their appearance in textbooks. By the 1890’s all three theorems were appearing in the analysis texts of many different authors. The third of

our theorems was always attributed to Stokes. The French and Russian authors tended to attribute the first theorem to Ostrogradsky, while others generally attributed it to Green or Gauss; this is still the case today. Similarly, Riemann is generally credited with the second theorem by the French, while Green is named by most others. Before Cartan's 1945 book, about the only author to attribute that result to Cauchy was H. Vogt in [26].

The generalized Stokes' theorem, first published, as we have seen, in 1945, has only been appearing in textbooks in the past twenty years, the first occurrence probably being in the 1959 volume of Nickerson, Spencer, and Steenrod [14].

## References

- [1] R. C. Buck, *Advanced Calculus*, 2nd ed., McGraw-Hill, New York, 1965.
- [2] E. Cartan, Sur certaines expressions différentielles et sur le problème de Pfaff, *Annales École Normale*, v. 16, 1899, pp. 239–332; *Oeuvres*, Part II, Vol. I, pp. 303–397.
- [3] E. Cartan, *Leçons sur les invariants intégraux*, Chap. VII, Hermann, Paris, 1922.
- [4] E. Cartan, *Les Systèmes Différentiels Extérieurs et leurs Applications Géométriques*, Hermann, Paris, 1945.
- [5] A. Cauchy, Sur les intégrales qui s'étendent à tous les points d'une courbe fermée, *Comptes Rendus*, v. 23, 1846, pp. 251–55; *Oeuvres*, Ire Série, Tome X, pp. 70–74.
- [6] T. DeDonder, Étude sur les invariants intégraux, *Rendiconti del Circolo Matematico di Palermo*, v. 16, 1902, pp. 155–179.
- [7] H. Flanders, *Differential Forms*, Academic Press, New York, 1963.
- [8] C. F. Gauss, *Theoria Attractionis Corporum Sphaeroidicorum Ellipticorum Homogeneorum Methodo nova tractata*, *Commentationes societatis regiae scientiarum Gottingensis recentiores*, v. II, 1813; *Werke*, v. 5, pp. 1–22.
- [9] G. Green, *An Essay on the Application of Mathematical Analysis to the Theories of Electricity and Magnetism*, London, 1828; *Green's Mathematical Papers*, pp. 3–115.
- [10] H. Hankel, *Zur allgemeinen Theorie der Bewegung der Flüssigkeiten*, Dieterische Univ. Buchdruckerei, Göttingen, 1861.
- [11] E. Kähler, *Einführung in die Theorie der Systeme von Differentialgleichungen*, Leipzig, 1934.
- [12] C. Maxwell, Letter to Stokes in G. Stokes, *Memoir and Scientific Correspondence*, ed. by J. Larmor, Cambridge, 1907, v. II, p. 31.
- [13] C. Maxwell, *A Treatise on Electricity and Magnetism*, Oxford, 1873, v. I.
- [14] H. Nickerson, D. Spencer, N. Steenrod, *Advanced Calculus*, Van Nostrand, Princeton, 1959.
- [15] M. Ostrogradsky, Démonstration d'un théorème du calcul intégral, pub. in Russian in *Istoriko-Matematicheskie Issledovania*, v. XVI, 1965, pp. 49–96.
- [16] M. Ostrogradsky, Note sur la Théorie de la Chaleur, *Mémoires de L'Acad. Imp. des Sciences de St. Petersburg*, ser. 6, v. 1, 1831, pp. 129–133.
- [17] M. Ostrogradsky, Sur le calcul des variations des intégrales multiples, *Journal für die Reine und angewandte Mathematik*, v. XV, 1836, pp. 332–354.
- [18] H. Poincaré, *Les Méthodes Nouvelles de la Mécanique Céleste*, v. III, p. 10, Gauthier-Villars, Paris, 1899, Dover, N.Y. 1957.
- [19] S. Poisson, Mémoire sur l'Équilibre et le Mouvement des Corps Élastiques, *Mémoires de l'Académie Royale des Sciences de l'Institut de France*, v. VIII, 1829, pp. 357–571.
- [20] B. Riemann, *Grundlagen für eine allgemeine Theorie der Functionen einer veränderlichen complexen Grösse*, Göttingen, 1851; *Werke*, pp. 3–48.
- [21] F. Sarrus, Mémoire sur les oscillations des corps flottans, *Annales de mathématiques pures et appliquées* (Nismes), v. XIX, 1828, pp. 185–211.
- [22] G. Stokes, *Mathematical and Physical Papers*, v. 5, p. 320, Cambridge Univ. Press, Cambridge, 1905.
- [23] P. Tait, On Green's and other allied Theorems, *Transactions of the Royal Society of Edinburgh*, 1869–70, pp. 69–84.
- [24] A. Taylor, W. Mann, *Advanced Calculus*, 2nd. ed., Xerox, Lexington, 1972.
- [25] W. Thomson, P. Tait, *Treatise on Natural Philosophy*, Vol. 1, Oxford, 1867.
- [26] H. Vogt, *Éléments de Mathématiques Supérieures*, Paris, 1925.
- [27] V. Volterra, Delle Variabili Complesse Negli Iperspazi, *Rendiconti della R. Accad. der Lincei*, ser. IV, v. V, 1889, pp. 158–165; *Opere*, v. I, pp. 403–411.
- [28] A. Yushkevich, *Istoriya Matematiki v Rossii do 1917 goda*, Moscow, 1968, p. 290.