

On Minuscule Representations and the Principal SL_2

Benedict H. Gross

In this paper, we review the theory of minuscule coweights λ for a simple adjoint group G over \mathbf{C} , as presented by Deligne [D]. We then decompose the associated irreducible representation V_λ of the dual group \hat{G} , when restricted to a principal SL_2 . This decomposition is given by the action of a Lefschetz SL_2 on the cohomology of the flag variety $X = G/P_\lambda$, where P_λ is the maximal parabolic subgroup of G associated to the coweight λ . We reinterpret a result of Vogan and Zuckerman [V-Z, Prop 6.19] to show that the cohomology of X is mirrored by the bigraded cohomology of the L -packet of discrete series with infinitesimal character ρ , for a real form G_0 of G with a Hermitian symmetric space.

We then focus our attention on those minuscule representations with a non-zero linear form $t : V \rightarrow \mathbf{C}$ fixed by the principal SL_2 , such that the subgroup $\hat{H} \subset \hat{G}$ fixing t acts irreducibly on the subspace $V_0 = \ker(t)$. We classify them in §10; since \hat{H} turns out to be reductive, we have a decomposition

$$V = \mathbf{C}e + V_0$$

where e is fixed by \hat{H} , and satisfies $t(e) \neq 0$. We study V as a representation of \hat{H} , and give an \hat{H} -algebra structure on V with identity e .

The rest of the paper studies representations π of G which are lifted from H , in the sense of Langlands. We show this lifting is detected by linear forms on π which are fixed by a certain subgroup L of G . The subgroup L descends to a subgroup $L_0 \rightarrow G_0$ over \mathbf{R} ; both have Hermitian symmetric spaces \mathcal{D} with $\dim_{\mathbf{C}}(\mathcal{D}_L) = \frac{1}{2} \dim_{\mathbf{C}}(\mathcal{D}_G)$. We hope this will provide cycle classes in the Shimura varieties associated to G_0 , which will enable one to detect automorphic forms in cohomology which are lifted from H .

It is a pleasure to thank Robert Kottwitz, Mark Reeder, Gordon Savin, and David Vogan for their help.

Table of Contents

1. Minuscule coweights
2. The real form G_0
3. The Weyl group
4. The flag variety
5. The representation V of the dual group \hat{G}
6. The principal $SL_2 \rightarrow \hat{G}$
7. Examples
8. Discrete series and a mirror theorem
9. Discrete series for $SO(2, 2n)$
10. A classification theorem: $V = \mathbf{C}e + V_0$
11. The representation V of \hat{H}
12. Representations of G lifted from H
13. The proof of Proposition 12.4
14. The real form of $L \rightarrow G$
15. Bibliography

1. Minuscule coweights

Let G be a simple algebraic group over \mathbf{C} , of adjoint type. Let $T \subset B \subset G$ be a maximal torus, contained in a Borel subgroup, and let Δ be the corresponding set of simple roots for T . Then Δ gives a \mathbf{Z} -basis for $\text{Hom}(T, \mathbf{G}_m)$, so a coweight λ in $\text{Hom}(\mathbf{G}_m, T)$ is completely determined by the integers $\langle \lambda, \alpha \rangle$, for α in Δ , which may be arbitrary. Let P_+ be the cone of dominant co-weights, where $\langle \lambda, \alpha \rangle \geq 0$ for all $\alpha \in \Delta$.

A coweight $\lambda : \mathbf{G}_m \rightarrow T$ gives a \mathbf{Z} -grading \mathfrak{g}_λ of $\mathfrak{g} = \text{Lie}(G)$, defined by

$$\mathfrak{g}_\lambda(i) = \{X \in \mathfrak{g} : \text{Ad } \lambda(a)(X) = a^i \cdot X\}$$

We say λ is minuscule provided $\lambda \neq 0$ and the grading \mathfrak{g}_λ satisfies $\mathfrak{g}_\lambda(i) = 0$ for $|i| \geq 2$. Thus

$$(1.1) \quad \mathfrak{g} = \mathfrak{g}_\lambda(-1) + \mathfrak{g}_\lambda(0) + \mathfrak{g}_\lambda(1).$$

The Weyl group $N_G(T)/T = W$ of T acts on the set of minuscule coweights, and the W -orbits are represented by the dominant minuscule coweights. These have been classified

Proposition 1.2 ([D, 1.2]). *The element λ is a dominant, minuscule coweight if and only if there is a single simple root α with $\langle \lambda, \alpha \rangle = 1$, the root α has multiplicity 1 in the highest root β , and all other simple roots α' satisfy $\langle \lambda, \alpha' \rangle = 0$.*

Thus, the W -orbits of minuscule coweights correspond bijectively to simple roots α with multiplicity 1 in the highest root β . If λ is minuscule and dominant, $\mathfrak{g}_\lambda(1)$ is the direct sum of the positive root spaces \mathfrak{g}_γ , where γ is a positive root containing α with multiplicity 1. Hence the dimension N of $\mathfrak{g}_\lambda(1)$ is given by the formula

$$(1.3) \quad N = \dim \mathfrak{g}_\lambda(1) = \langle \lambda, 2\rho \rangle,$$

where ρ is half the sum of the positive roots.

The subgroup $W_\lambda \subset W$ fixing λ is isomorphic to the Weyl group of T in the subalgebra $\mathfrak{g}_\lambda(0)$, which has root basis $\Delta - \{\alpha\}$. We now tabulate the W -orbits of minuscule coweights,

by listing the simple α occurring with multiplicity 1 in β in the numeration of Bourbaki [B]. We also tabulate $N = \dim \mathfrak{g}_\lambda(1)$ and $(W : W_\lambda)$; a simple comparison show that $(W : W_\lambda) \geq N + 1$ in all cases; we will explain this inequality later.

Table 1.4

G	α	$(W : W_\lambda)$	N
A_ℓ	α_k	$\binom{\ell+1}{k}$	$k(\ell + 1 - k)$
	$1 \leq k \leq \ell$		
B_ℓ	α_1	2^ℓ	$2\ell - 1$
C_ℓ	α_ℓ	2^ℓ	$\frac{\ell(\ell+1)}{2}$
D_ℓ	α_1	2^ℓ	$2\ell - 2$
	$\alpha_{\ell-1}, \alpha_\ell$	$2^{\ell-1}$	$\frac{\ell(\ell-1)}{2}$
E_6	α_1, α_6	27	16
E_7	α_1	56	27

2. The real form G_0

We henceforth fix G and a dominant minuscule coweight λ . Let G_c be the compact real form for G , so $G = G_c(\mathbf{C})$ and $G_c(\mathbf{R})$ is a maximal compact subgroup of G . Let $g \mapsto \bar{g}$ be the corresponding conjugation of G .

Let $T_c \subset G_c$ be a maximal torus over \mathbf{R} . We have an identification of co-character groups

$$\mathrm{Hom}_{\mathrm{cont}}(S^1, T_c(\mathbf{R})) = \mathrm{Hom}_{\mathrm{alg}}(\mathbf{G}_m, T).$$

We view λ as a homomorphism $S^1 \rightarrow T_c(\mathbf{R})$, and define

$$(2.1) \quad \theta = \mathrm{ad} \lambda(-1) \quad \text{in} \quad \mathrm{Inn}(G).$$

Then θ is a Cartan involution, which gives another descent G_0 of G to \mathbf{R} . The group G_0 has real points

$$G_0(\mathbf{R}) = \{g \in G : \bar{g} = \theta(g)\},$$

and a maximal compact subgroup K of $G_0(\mathbf{R})$ is given by

$$\begin{aligned} K &= \{g \in G : g = \bar{g} \quad \text{and} \quad g = \theta(g)\} \\ &= G_0(\mathbf{R}) \cap G_c(\mathbf{R}). \end{aligned}$$

The corresponding decomposition of the complex Lie algebra \mathfrak{g} under the action of K is given by $\mathfrak{g} = \mathfrak{k} + \mathfrak{p}$, with

$$(2.2) \quad \begin{cases} \mathfrak{k} = \mathrm{Lie}(K) \otimes \mathbf{C} = \mathfrak{g}_\lambda(0) \\ \mathfrak{p} = \mathfrak{g}_\lambda(-1) + \mathfrak{g}_\lambda(1). \end{cases}$$

The torus $\lambda(S^1)$ lies in the center of the connected component of K , and the element $\lambda(i)$ gives the symmetric space

$$\mathcal{D} = G_0(\mathbf{R})/K$$

a complex structure, with

$$(2.3) \quad N = \dim_{\mathbf{C}}(\mathcal{D}).$$

Proposition 2.4. ([D, 1.2]). *The real Lie groups $G_0(\mathbf{R})$ and K have the same number of connected components, which is either 1 or 2. Moreover, the following are all equivalent:*

- 1) $G_0(\mathbf{R})$ has 2 connected components.
- 2) The symmetric space \mathcal{D} is a tube domain.
- 3) The vertex of the Dynkin diagram of G corresponding to the simple root α is fixed by the opposition involution of the diagram.
- 4) The subgroup W_λ fixing λ has a nontrivial normalizer in W , consisting of those w with $w\lambda = \pm\lambda$.

In fact, the subgroup $W_c \subset W$ which normalizes W_λ is precisely the normalizer of the compact torus $T_c(\mathbf{R})$ in $G_0(\mathbf{R})$. When $W_\lambda \neq W_c$, it is generated by W_λ and the longest element w_0 , which satisfies $w_0\lambda = -\lambda$.

As an example, let $G = SO_3$ and

$$\lambda(t) = \begin{pmatrix} t & & \\ & 1 & \\ & & t^{-1} \end{pmatrix}.$$

Then θ is conjugation by

$$\lambda(-1) = \begin{pmatrix} -1 & & \\ & 1 & \\ & & -1 \end{pmatrix},$$

and $G_0 = SO(1, 2)$ has 2 connected components. We have $K \simeq O(2)$, $W_c = W$ has order 2 in this case, and $W_\lambda = 1$. The tube domain $\mathcal{D} = G_0(\mathbf{R})/K$ is isomorphic to the upper half plane.

3. The Weyl group (cf. [H])

The Weyl group W is a Coxeter group, with generating reflections s corresponding to the simple roots in Δ . Recall that ρ is half the sum of the positive roots and $W_\lambda \subset W$ is the subgroup fixing λ .

Proposition 3.1. *Each coset wW_λ of W_λ in W has a unique representative y of minimal length. The length $d(y)$ of the minimal representative is given by the formula:*

$$d(y) = \langle \lambda, \rho \rangle - \langle w\lambda, \rho \rangle,$$

where w is any element in the coset.

Proof. Let R^\pm be the positive and negative roots, let R_λ^\pm be the subsets of positive and negative roots which satisfy $\langle \lambda, \gamma \rangle = 0$. Then $R^+ - R_\lambda^+$ consists of the roots with $\langle \lambda, \gamma \rangle = 1$, and $R^- - R_\lambda^-$ consists of the roots with $\langle \lambda, \gamma \rangle = -1$. These sets are stable under the action of W_λ on R . On the other hand, if $w \in W_\lambda$ stabilizes R_λ^+ (or R_λ^-) then $w = 1$, as W_λ is the Weyl group of the root system $R_\lambda = R_\lambda^+ \cup R_\lambda^-$.

Since the length $d(y)$ of y in W is given by

$$(3.2) \quad d(y) = \#\{\gamma \text{ in } R^+ : y^{-1}(\gamma) \text{ is in } R^-\},$$

the set

$$(3.3) \quad Y = \{y \in W : y(R_\lambda^+) \subset R^+\}$$

gives coset representatives for W_λ of minimal length. Moreover, for $y \in Y$ the set $y^{-1}(R^+)$ contains $d(y)$ elements of R_λ^- , and hence $N - d(y)$ elements of R_λ^+ . Hence, if $wW_\lambda = yW_\lambda$, we find

$$\begin{aligned} \langle w\lambda, \rho \rangle &= \langle y\lambda, \rho \rangle = \langle \lambda, y^{-1}\rho \rangle \\ &= \frac{1}{2}((N - d(y)) - d(y)) \\ &= \frac{1}{2}N - d(y). \end{aligned}$$

Since

$$\langle \lambda, \rho \rangle = \frac{1}{2}N,$$

we obtain the desired formula.

As an example of Proposition 3.1, the minimal representative of W_λ is $y = 1$, with $d(y) = 0$, and the minimal representative of $s_\alpha W_\lambda$ is $y = s_\alpha$, with $d(y) = 1$. If w_0 is the longest element in the Weyl group, then $w_0(R^\pm) = R^\mp$, so $w_0^2 = 1$, and $w_0\rho = -\rho$. Hence

$$\langle w_0\lambda, \rho \rangle = \langle \lambda, w_0^{-1}\rho \rangle = -\langle \lambda, \rho \rangle = -N/2.$$

Consequently, the length of the minimal representative y of w_0W_λ is $d(y) = N$. This is the maximal value of d on W/W_λ , and we will soon see that d takes all integral values in the interval $[0, N]$.

Assume λ is fixed by the opposition involution $-w_0$, so $w_0\lambda = -\lambda$. Then \mathcal{D} is a tube domain, and W_λ has nontrivial normalizer $W_c = \langle W_\lambda, w_0 \rangle$ in W , by Proposition 2.4. The 2-group W_c/W_λ acts on the set W/W_λ by $wW_\lambda \mapsto ww_0W_\lambda$, and this action has no fixed points. Hence we get a fixed point-free action $y \mapsto y^*$ on the set Y , and find:

$$(3.4) \quad d(y) + d(y^*) = N.$$

4. The flag variety

Associated to the dominant minuscule coweight λ is a maximal parabolic subgroup P , which contains B and has Lie algebra

$$(4.1) \quad \text{Lie}(P) = \mathfrak{g}_\lambda(0) + \mathfrak{g}_\lambda(1).$$

The flag variety $X = G/P$ is projective, of complex dimension N .

The cohomology of X is all algebraic, so $H^{2n+1}(X) = 0$ for all $n \geq 0$. Let

$$(4.2) \quad f_X(t) = \sum_{n \geq 0} \dim H^{2n}(X) \cdot t^n$$

be the Poincaré polynomial of $H^*(X)$. Then we have the following consequence of Chevalley-Bruhat theory, which also gives a convenient method of computing the values of the function $d : W/W_\lambda \rightarrow \mathbf{Z}$.

Proposition 4.3. 1) *We have $f_X(t) = \sum_Y t^{d(y)}$.*

2) *If \underline{G} is the split adjoint group over \mathbf{Z} with the same root datum as G , and \underline{P} is the standard parabolic corresponding to λ , then*

$$f_X(q) = \#\underline{G}(F)/\underline{P}(F)$$

for all finite fields F , with $q = \#F$.

3) *The Euler characteristic of X is given by*

$$\chi = f_X(1) = \#(W : W_\lambda).$$

Proof. We have the decomposition

$$G = \bigcup_Y ByP,$$

where we have chosen a lifting of y from W to $N_G(T)$. If U is the unipotent radical of B , then $B = UT$. Since y normalizes T ,

$$UyP = ByP.$$

This gives a cell decomposition

$$X = \bigcup_Y Uy/P \cap y^{-1}Uy$$

where the cell corresponding to y is an affine space of dimension $d(y)$. This gives the first formula.

The formula for $f_X(q)$ follows from the Bruhat decomposition, which can be used to prove the Weil conjectures for X . Formula 3) for $f_X(1)$ follows immediately from 1).

For an example, let $G = PSp_{2n}$ be of type C_n . Then P is the Siegel parabolic subgroup, with Levi factor GL_n/μ_2 . From the orders of $Sp_{2n}(q)$ and $GL_n(q)$, we find

$$\begin{aligned} \#\underline{G}(F)/\underline{P}(F) &= \frac{(q^2 - 1)(q^4 - 1) \dots (q^{2n} - 1)}{(q - 1)(q^2 - 1) \dots (q^n - 1)} \\ &= (1 + q)(1 + q^2) \dots (1 + q^n). \end{aligned}$$

Hence we find

$$(4.4) \quad f_X(t) = (1 + t)(1 + t^2) \dots (1 + t^n).$$

The fact that $X = G/P$ is a Kahler manifold imposes certain restrictions on its cohomology. For example, if ω is a basis of $H^2(X)$, then $\omega^k \neq 0$ in $H^{2k}(X)$ for all $0 \leq k \leq N$. Hence we find that

Corollary 4.5. *The function $d : W/W_\lambda \rightarrow \mathbf{Z}$ takes all integral values in $[0, N]$, and $(W : W_\lambda) \geq N + 1$.*

For $0 \leq k \leq N$, let

$$m(k) = \#\{y \in Y : d(y) = k\}.$$

We have seen that $m(0) = m(1) = 1$ in all cases. By Poincaré duality

$$(4.6) \quad m(k) = m(N - k).$$

Finally, the Lefschetz decomposition into primitive cohomology shows that:

$$(4.7) \quad m(k - 1) \leq m(k)$$

whenever $2k \leq N$. Indeed, the representation of the Lefschetz SL_2 on $H^*(G/P)$ has weights $N - 2d(y)$ for the maximal torus $\begin{pmatrix} t & 0 \\ 0 & t^{-1} \end{pmatrix}$.

5. The representation V of the dual group \hat{G}

Let \hat{G} be the Langlands dual group of G , which is simply-connected of the dual root type. This group comes (in its construction) with subgroups $\hat{T} \subset \hat{B} \subset \hat{G}$, and an identification of the positive roots for \hat{B} in $\text{Hom}(\hat{T}, \mathbf{G}_m)$ with the positive co-roots for B in $\text{Hom}(\mathbf{G}_m, T)$ (cf. [G]). Hence, the dominant co-weights for T give dominant weights for \hat{T} , which are the highest weights for \hat{B} on irreducible representations of \hat{G} .

Let V be the irreducible representation of \hat{G} , whose highest weight for \hat{B} is the dominant, minuscule co-weight λ .

Proposition 5.1. *The weights of \hat{T} on V consist of the elements in the W -orbit of λ . Each has multiplicity 1, so $\dim V = (W : W_\lambda)$.*

The central character χ of V is given by the image of λ in $\text{Hom}(\hat{T}, \mathbf{G}_m) / \bigoplus_{\Delta} \mathbf{Z}\alpha^\vee$, and is nontrivial.

Proof. For μ and λ dominant, we write $\mu \leq \lambda$ if $\lambda - \mu$ is a sum of positive co-roots. These are precisely the other dominant weights for \hat{T} occurring in V_λ . When λ is minuscule, $\mu \leq \lambda$ implies $\mu = \lambda$, so only the W -orbit of λ occur as weights. Each has the same multiplicity as the highest weight, which is 1. Since $\mu = 0$ is dominant, λ is not in the span of the co-roots, and $\chi \neq 1$.

This result gives another proof of the inequality of Corollary 4.5: $(W : W_\lambda) \geq N + 1$. Indeed, let L be the unique line in V_λ fixed by \hat{B} . The fixer of L is the standard parabolic \hat{P} dual to P . This gives an embedding of projective varieties:

$$\hat{G}/\hat{P} \hookrightarrow \mathbf{P}(V_\lambda).$$

Since \hat{G}/\hat{P} has dimension N , and $\mathbf{P}(V_\lambda)$ has dimension $(W : W_\lambda) - 1$, this gives the desired inequality.

The real form G_0 defined in §2 has Langlands L -group

$$(5.2) \quad {}^L G = \hat{G} \times \text{Gal}(\mathbf{C}/\mathbf{R}).$$

The action of $\text{Gal}(\mathbf{C}/\mathbf{R})$ on \hat{G} exchanges the irreducible representation V with dominant weight λ with the dual representation V^* with dominant weight $-w_0\lambda$. Hence the sum $V + V^*$ always extends to a representation of ${}^L G$. The following is a simple consequence of Proposition 2.4.

Proposition 5.3. *The following are equivalent:*

- 1) *We have $w_0\lambda = -\lambda$.*
- 2) *The symmetric space \mathcal{D} is a tube domain.*
- 3) *The representation V is isomorphic to V^* .*
- 4) *The central character χ of V satisfies $\chi^2 = 1$.*
- 5) *The representation V of \hat{G} extends to a representation of ${}^L G$.*

The principal $SL_2 \rightarrow \hat{G}$

The group \hat{G} also comes equipped with a principal $\varphi : SL_2 \rightarrow \hat{G}$ [G]. The co-character $\mathbf{G}_m \rightarrow \hat{T}$ given by the restriction of φ to the maximal torus $\begin{pmatrix} t & 0 \\ 0 & t^{-1} \end{pmatrix}$ of SL_2 is equal to 2ρ in $\text{Hom}(\mathbf{G}_m, \hat{T}) = \text{Hom}(T, \mathbf{G}_m)$. From this, and Proposition 5.1, we conclude the following.

Proposition 6.1. *The restriction of the minuscule representation V to the principal SL_2 in \hat{G} has weights*

$$\bigoplus_{W/W_\lambda} t^{\langle w\lambda, 2\rho \rangle}$$

for the maximal torus $\begin{pmatrix} t & 0 \\ 0 & t^{-1} \end{pmatrix}$ in SL_2 .

On the other hand, by Proposition 3.1, we have

$$(6.2) \quad \langle w\lambda, 2\rho \rangle = \langle \lambda, 2\rho \rangle - 2d(y) = N - 2d(y)$$

where $d(y)$ is the length of the minimal representative y in the coset wW_λ . Hence the weights for the principal SL_2 acting on V are the integers

$$(6.3) \quad N - 2d(y) \quad y \in Y$$

in the interval $[-N, N]$. Since these are also the weights of the Lefschetz SL_2 acting on the cohomology $H^*(G/P)$ by §4, we obtain the following.

Corollary 6.4. *The representation of the principal SL_2 of \hat{G} on V is isomorphic to the representation of the Lefschetz SL_2 on the cohomology of the flag variety $X = G/P$.*

7. Examples

We now give several examples of the preceding theory, using the notation for roots and weights of [B].

If G is of type A_ℓ and $\alpha = \alpha_1$ we have $\lambda = e_1$. The flag variety G/P is projective space \mathbf{P}^N , with $N = \ell$, and the Poincaré polynomial is $1 + t + t^2 + \cdots + t^N$. The dual group \hat{G} is SL_{N+1} , and V is the standard representation. The restriction of V to a principal SL_2 is irreducible, isomorphic to $S^N = \text{Sym}^N(\mathbf{C}^2)$.

A similar result holds when G is of type B_ℓ , so $\alpha = \alpha_1$ and $\lambda = e_1$. Here G/P is a quadric of dimension $N = 2\ell - 1$, with $P(t) = 1 + t + \cdots + t^N$ as before. The dual group is $\hat{G} = \text{Sp}_{2\ell}$, the representation V is the standard representation, and its restriction to the principal SL_2 is the irreducible representation S^N .

Next, suppose G is of type D_ℓ and $\alpha = \alpha_1$, so $\lambda = e_1$. Then G/P is a quadric of dimension $N = 2\ell - 2$, and we have $P(t) = 1 + t + \cdots + 2t^{\ell-1} + \cdots + t^N$. The dual group \hat{G} is $\text{Spin}_{2\ell}$, and V is the standard representation of the quotient $SO_{2\ell}$. Its restriction to the principal SL_2 is a direct sum $S^N + S^0$, where S^0 is the trivial representation.

A more interesting case is when G is of type C_ℓ , so $\alpha = \alpha_\ell$ and $\lambda = \frac{e_1 + e_2 + \cdots + e_\ell}{2}$. Here G/P is the Lagrangian Grassmanian of dimension $N = \frac{\ell(\ell+1)}{2}$, and $P(t) = (1+t)(1+t^2)\cdots(1+t^\ell)$ was calculated in (4.4). The dual group \hat{G} is $\text{Spin}_{2\ell+1}$, and V is the spin representation of dimension 2^ℓ . Its decomposition to a principal SL_2 is given by §6, and we find the following representations, for $\ell \leq 6$.

$$\begin{aligned}
 (7.1) \quad & S^1 && \ell = 1 \\
 & S^3 && \ell = 2 \\
 & S^6 + S^0 && \ell = 3 \\
 & S^{10} + S^4 && \ell = 4 \\
 & S^{15} + S^9 + S^5 && \ell = 5 \\
 & S^{21} + S^{15} + S^{11} + S^9 + S^3 && \ell = 6
 \end{aligned}$$

As the last example, suppose G is of type E_6 . Then G/P has dimension 16 and Poincaré polynomial

$$P(t) = 1 + t + t^2 + t^3 + 2t^4 + 2t^5 + 2t^6 + 2t^7 + 3t^8 \\ + 2t^9 + 2t^{10} + 2t^{11} + 2t^{12} + t^{13} + t^{14} + t^{15} + t^{16}.$$

The representation V has dimension 27, and its restriction to a principal SL_2 is the representation

$$(7.2) \quad S^{16} + S^8 + S^0.$$

Proposition 7.3. *The representation V of the principal SL_2 is irreducible, hence isomorphic to S^N , if and only if G is of type A_ℓ or B_ℓ and $\alpha = \alpha_1$.*

The representation V of the principal SL_2 is isomorphic to $S^N + S^0$ if and only if G is of type D_ℓ and $\alpha = \alpha_1$, or G is of type D_4 and $\alpha = \alpha_3$ or α_4 , or G is of type C_3 and $\alpha = \alpha_3$.

Proof. The condition $V = S^N$ as a representation of SL_2 is equivalent to the equality

$$\dim V = (W : W_\lambda) = N + 1.$$

The condition $V = S^N + S^0$ as a representation of SL_2 is equivalent to the equality

$$\dim V = (W : W_\lambda) = N + 2.$$

One obtains all the above cases by a consideration of the columns in Table 1.4.

8. Discrete series and a mirror theorem

Let G_0 be the real form of G described in §2, and let $G_0(\mathbf{R})^+$ be the connected component of $G_0(\mathbf{R})$. The L -packet of discrete series representations π^+ of $G_0(\mathbf{R})^+$ with infinitesimal character the W -orbit of ρ is in canonical bijection with the coset space W_λ/W . Indeed, W_λ is the compact Weyl group of the simply-connected algebraic cover G_0^{sc} of G_0 , and any discrete series for $G_0^{sc}(\mathbf{R})$ with infinitesimal character ρ has trivial central character, so descends to the quotient group $G_0(\mathbf{R})^+$. On the other hand, such discrete series for $G_0^{sc}(\mathbf{R})$ are parameterized by their Harish-Chandra parameters in $\text{Hom}(T_c^{sc}(\mathbf{R}), S^1)/W_\lambda$, which lie in the W -orbit of ρ . The coset $W_\lambda\rho$ corresponds to the holomorphic discrete series, and the coset $W_\lambda w_0\rho = W_\lambda w_0^{-1}\rho$ corresponds to the anti-holomorphic discrete series.

Proposition 8.1. ([V-Z, Prop. 6.19]) *Assume that the discrete series π^+ of $G_0(\mathbf{R})^+$ has Harish-Chandra parameter $W_\lambda w^{-1}\rho$. Then π^+ has bigraded cohomology*

$$H^{p,q}(\mathfrak{g}, K^+; \pi^+) \simeq \mathbf{C}$$

for $p + q = N$ and $q = d(y)$, the length of the minimal representative of wW_λ . The cohomology of π vanishes in all other bidegrees (p', q') .

Proof. The bigrading of the (\mathfrak{g}, K^+) cohomology of any π^+ in the L -packet is discussed in [V-Z, (6.18)(a-c)]. The cohomology has dimension 1 for degree N , and dimension 0 otherwise, so we must have $p + q = N$.

On the other hand, Arthur (cf. [A, pgs. 62–63]) interprets the calculation of [V-Z, Prop 6.19] to obtain the formula:

$$-\frac{1}{2}(p - q) = \langle \lambda, w^{-1}\rho \rangle = \langle w\lambda, \rho \rangle.$$

Since $\frac{1}{2}(p + q) = \langle \lambda, \rho \rangle$, we find that $q = \langle \lambda, \rho \rangle - \langle w\lambda, \rho \rangle = d(y)$, by Proposition 3.1.

If $G_0(\mathbf{R}) \neq G_0(\mathbf{R})^+$, the discrete series π for $G_0(\mathbf{R})$ with infinitesimal character ρ correspond to the coset space W_c/W , where W_c is the (nontrivial) normalizer of W_λ in

W . We find that the bigraded cohomology of π with Harish-Chandra parameter $W_c w^{-1} \rho$ is the direct sum of two lines of type (p, q) and (q, p) , with $p + q = N$ and $q = d(y)$.

The 2-group K/K^+ acts on $H^N(\mathfrak{g}, K^+, \pi)$, switching the two lines. When $p = q = N/2$, there is a unique line in $H^{p,p}(\mathfrak{g}, K^+, \pi)$ fixed by K/K^+ .

A suggestive way to restate the calculation of the bigraded cohomology is the following.

Corollary 8.2. *The Hodge structure on the sum $H^N(G_0) = \bigoplus_{\pi} H^{*,*}(\mathfrak{g}, K^+, \pi)$ over the L -packet of discrete series for $G_0(\mathbf{R})$ with infinitesimal character ρ mirrors the Hodge structure on $H^*(G/P)$. That is:*

$$\dim H^{q,q}(G/P) = \dim H^{N-q,q}(G_0)$$

Indeed, both dimensions are equal to the number of classes wW_λ in W/W_λ with $d(w, W_\lambda) = q$.

9. Discrete series for $SO(2, 2n)$

Assume that G is of type D_{n+1} , with $n \geq 2$, and that $\alpha = \alpha_1$. The group $G_0(\mathbf{R})$ is then isomorphic to $PSO(2, 2n) = SO(2, 2n)/\langle \pm 1 \rangle$, and \mathcal{D} is a tube domain of complex dimension $N = 2n$. There are $n + 1$ discrete series representations π of $G_0(\mathbf{R})$ with infinitesimal character ρ . We will describe these as representations of $SO(2, 2n)$, with trivial central character, and will calculate their minimal K^+ -types and Hodge cohomology.

Let V be a 2-dimensional real vector space, with a positive definite quadratic form, and write $-V$ for the same space, with the negative form. For $k = 0, 1, \dots, n$ define the quadratic space

$$W_k = V_0 + V_1 + \cdots + (-V_k) + \cdots + V_n,$$

so $SO(W_k) \simeq SO(2, 2n)$, a maximal compact torus T_c in $SO(W_k)$ is given by $\prod_{i=0}^n SO(V_i)$, and a maximal compact, connected subgroup K^+ containing T_c is given by $SO(V_k) \times SO(V_k^\perp)$. If e_i is a generator of $\text{Hom}(SO(V_i), S^1)$, then the character group of T_c is $\bigoplus_{i=0}^n \mathbf{Z}e_i$, and the roots of T_c on \mathfrak{g} are the elements

$$\gamma_{ij} = \pm e_i \pm e_j \quad i \neq j.$$

The compact roots of T_c on k are those roots γ_{ij} with $i \neq k + 1$ and $j \neq k + 1$, so the $(k + 1)$ st coordinate of γ is zero.

A set of positive roots is given by

$$R^+ = \{e_i \pm e_j : i < j\}.$$

This has root basis

$$\Delta = \{e_0 - e_1, e_1 - e_2, \dots, e_{n-1} - e_n, e_{n-1} + e_n\}$$

and

$$\rho = (n, n - 1, n - 2, \dots, 1, 0).$$

On the other hand, half the sum ρ_c of the compact positive roots is given by

$$\rho_c = (n-1, n-2, \dots, n-k, 0, n-k-1, k, \dots, 1, 0).$$

At the two extremes, we find:

$$k=0 \quad \rho_c = (0, n-1, n-2, \dots, 1, 0)$$

$$k=n \quad \rho_c = (n-1, n-2, \dots, 1, 0, 0).$$

The lowest K^+ -type of a discrete series π^+ for $SO(2, 2n)^+$ with Harish-Chandra parameter $\lambda = \rho$ is given by Schmid's formula:

$$\lambda + \rho - 2\rho_c = 2(\rho - \rho_c).$$

For the realizations $SO(2, 2n) \simeq SO(W_k)$ above, we obtain $n+1$ discrete series π_k^+ with minimal $K^+ \simeq SO(2) \times SO(2n)$ type

$$\chi^{2(n-k)} \otimes \underbrace{(2, 2, 2, \dots, 2, 0, 0 \dots 0)}_{k \text{ times}}$$

where χ is the fundamental character of $SO(2)$, giving the action on \mathfrak{p}^+ . The irreducible representation of $SO(2n)$ with highest weight $2(e_1 + \dots + e_k)$ appears with multiplicity 1 in $\text{Sym}^2(\wedge^k \mathbf{C}^{2n})$, and the minimal K^+ -type appears with multiplicity 1 in the representation $\wedge^k \mathfrak{p}_- \otimes \wedge^{2n-k} \mathfrak{p}_+$. Hence the Hodge type of π_k^+ is $(2n-k, k)$.

Each discrete series π_k of $SO(2, 2n)$ with infinitesimal character ρ decomposes as $\pi_k = \pi_k^+ + \pi_k^-$ when restricted to $SO(2, 2n)^+$, with π_k^+ as above, and π_k^- its conjugate by $G_0(\mathbf{R})/G_0(\mathbf{R})^+$. The minimal K^+ -type of π_k^- is

$$\chi^{2(k-n)} \otimes \underbrace{(2, 2, 2, \dots, 2, 0, 0 \dots 0)}_{k \text{ times}}$$

so π_k^- has Hodge type $(k, 2n-k)$, and π_k has Hodge type $(k, 2n-k) + (2n-k, k)$.

If we label the simple roots in the Dynkin diagram for G : white for non-compact roots, black for compact roots, then the discrete series π_k of $SO(2, 2n)$ gives the labelled diagram

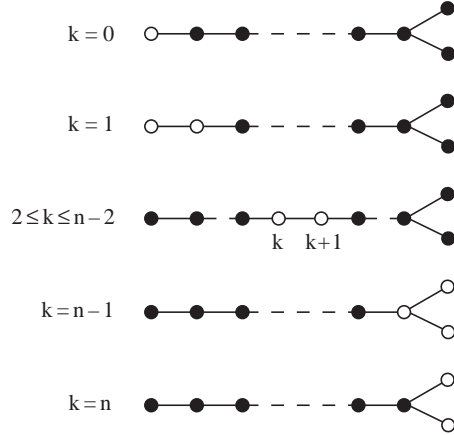

In the case $k = 0$, π_k is the sum of holomorphic and anti-holomorphic discrete series, and is an admissible representation of the subgroup $SO(2) \subset K^+$. In the case $k = n$, π_n is admissible for the subgroup $SO(2n) \subset K^+$, and has Hodge type $(n, n) + (n, n)$.

10. A classification theorem: $V = \mathbf{C}e + V_0$

We now return to the restriction of a minimal representation V of \hat{G} to a principal SL_2 in \hat{G} . Since V will be fixed, we will replace the simply-connected group \hat{G} by its quotient which acts *faithfully* on V , and will henceforth use the symbol \hat{G} for this subgroup of $GL(V)$. The group G is therefore no longer necessarily of adjoint type. We have

$$(10.1) \quad X_{\bullet}(T) = \mathbf{Z}\lambda + \bigoplus_{\text{co-roots}} \mathbf{Z}\alpha^{\vee}$$

and $\ell\lambda$ lies in the sublattice $\bigoplus \mathbf{Z}\alpha^{\vee}$, with ℓ the order of the (cyclic) center of \hat{G} . Since $\langle \alpha^{\vee}, \rho \rangle$ is an integer for all co-roots, we find that ρ is in $X^{\bullet}(T)$ if and only if $\langle \lambda, \rho \rangle$ is an integer. By (1.3) this occurs precisely when the integer $N = \dim_{\mathbf{C}}(\mathcal{D})$ is even. Since the center $\langle \pm 1 \rangle$ of a principal SL_2 in \hat{G} acts on V by the character $(-1)^N$, we see that ρ is in $X^{\bullet}(T)$ precisely when principal homomorphism $SL_2 \rightarrow \hat{G}$ factors through the quotient group PGL_2 .

Proposition 10.3. *Assume that there is a non-zero linear form $t : V \rightarrow \mathbf{C}$ which is fixed by the principal $SL_2 \rightarrow \hat{G}$, and that the subgroup \hat{H} of \hat{G} fixing t acts **irreducibly** on the hyperplane $V_0 = \ker(t)$.*

Then (up to the action of the outer automorphism group of the simply-connected cover of \hat{G}) the representation V is given by the following table

\hat{G}	V	\hat{H}
SL_{2n}/μ_2	$\overset{2}{\wedge} \mathbf{C}^{2n}$	Sp_{2n}/μ_2
SO_{2n}	\mathbf{C}^{2n}	SO_{2n-1}
E_6	\mathbf{C}^{27}	F_4
$Spin_7$	\mathbf{C}^8	G_2

Proof. By definition, \hat{H} contains the image of the principal SL_2 (which is isomorphic to PGL_2). These subgroups of simple \hat{G} have been classified by de Siebenthal [dS]. One has the chains:

$$SL_2 \rightarrow SO_{2n+1} \rightarrow SL_{2n+1}$$

$$SL_2 \rightarrow Sp_{2n} \rightarrow SL_{2n}$$

$$SL_2 \rightarrow SO_{2n-1} \rightarrow SO_{2n}$$

$$SL_2 \rightarrow F_4 \rightarrow E_6$$

$$SL_2 \rightarrow G_2 \rightarrow \text{Spin}_7 \rightarrow SO_8$$

$$SL_2 \rightarrow G_2 \rightarrow SO_7 \rightarrow SL_7$$

It is then a simple matter to check, for any V , whether an \hat{H} containing the principal SL_2 can act irreducibly on V_0 .

Beyond the examples given in Proposition 10.3, we have one semi-simple example with the same properties:

$$(10.4) \quad \hat{G} = SL_n^2 / \Delta\mu_n \quad V = \mathbf{C}^n \otimes (\mathbf{C}^n)^* \quad \hat{H} = PGL_n.$$

In all cases, \hat{H} is a group of adjoint type.

Proposition 10.5. *For the groups \hat{G} in Proposition 10.3, the center is cyclic of order $\ell \geq 2$. The integer ℓ is the number of irreducible representations in the restriction of V to a principal SL_2 .*

The \hat{G} -invariants in the symmetric algebra on V^ form a polynomial algebra, on one generator $d : V \rightarrow \mathbf{C}$ of degree ℓ . The group \hat{G} has an open orbit on the projective space of lines in V , with connected stabilizer \hat{H} , consisting of the lines where $d(v) \neq 0$.*

Proof. The first assertion is proved by an inspection of the following table. We derive the decomposition of V from §6.

Table 10.6

\hat{G}	$\ell = \text{order of center}$	decomp. of V
SL_{2n}/μ_2	$n \geq 2$	$S^{4n-4} + S^{4n-8} + \dots + S^4 + S^0$
SO_{2n}	2	$S^{2n-2} + S^0$
E_6	3	$S^{16} + S^8 + S^0$
Spin_7	2	$S^6 + S^0$
$SL_n^2/\Delta\mu_n$	$n \geq 2$	$S^{2n-2} + S^{2n-4} + \dots + S^2 + S^0$

The calculation of $S^\bullet(V^*)^{\hat{G}}$ follows from [S-K], which also identifies the connected component of the stabilizer with \hat{H} . Note that the degree of any invariant is divisible by ℓ , as the center acts faithfully on V^* .

11. The representation V of \hat{H}

Recall that $\ell \geq 2$ is the order of the cyclic center of \hat{G} , tabulated in 10.6. Since the subgroup $\hat{H} \subset \hat{G}$ fixing the linear form $t: V \rightarrow \mathbf{C}$ is reductive, we have a splitting of \hat{H} -modules

$$(11.1) \quad V = \mathbf{C}e + V_0$$

with $V_0 = \ker(t)$, and e a vector fixed by \hat{H} satisfying $t(e) \neq 0$. Once t has been chosen, we may normalize e by insisting that

$$(11.2) \quad t(e) = \ell.$$

Proposition 11.3. *The representation V_0 of \hat{H} is orthogonal. Its weights consist of the short roots of \hat{H} and the zero weight. The zero weight space for \hat{H} in V has dimension ℓ , and V is a polar representation of \hat{H} of type $A_{\ell-1}$: the \hat{H} -invariants in the symmetric algebra of $V \simeq V^*$ form a polynomial algebra, with primitive generators in degrees $1, 2, 3, \dots, \ell$.*

Proof. The fact that V_0 is orthogonal, and its weights, are obtained from a consideration of the table in Proposition 10.1. Since

$$\dim V = \ell + \#\{\text{short roots of } \hat{H}\},$$

this gives the dimension of the zero weight space.

Let $\hat{S} \subset \hat{H}$ be a maximal torus, with normalizer \hat{N} . The image of \hat{N}/\hat{S} in $GL(V^{\hat{S}}) = GL_{\ell}$ is the symmetric group Σ_{ℓ} . The fact that V is polar follows from the tables in [D-K], which also gives an identification of algebras: $S^{\bullet}(V)^{\hat{H}} \simeq S^{\bullet}(V^{\hat{S}})^{\hat{N}/\hat{S}}$. The latter algebra is generated by the elementary symmetric functions, of degrees $1, 2, 3, \dots, \ell$.

Note 11.4. The integer ℓ is also the number of distinct summands in the restriction of V to a principal SL_2 . Since each summand is an orthogonal representation of SL_2 , $\ell = \dim V^{\hat{S}_0}$, where $\hat{S}_0 \subset SL_2$ is a maximal torus. Hence $V^{\hat{S}_0} = V^{\hat{S}}$.

We will now define an \hat{H} -algebra structure on V , with identity element e , in a case by case manner. Although the multiplication law $V \otimes V \rightarrow V$ is not in general associative, it is power associative, and for $v \in V$ and $k \geq 0$ we can define v^k in V unambiguously. The primitive \hat{H} -invariants in $S^\bullet(V^*)$ can then be given by

$$(11.5) \quad v \mapsto t(v^k) \quad 1 \leq k \leq \ell.$$

In (11.5), $t: V \rightarrow \mathbf{C}$ is the \hat{H} -invariant linear form, normalized by the condition that

$$t(e) = \ell.$$

We will also identify the \hat{G} -invariant ℓ -form $\det: V \rightarrow \mathbf{C}$, normalized by the condition that

$$\det(e) = 1.$$

The simplest case, when the algebra structure on V is associative, is when $\hat{H} = PGL_n$ and V is the adjoint representation (of GL_n) on $n \times n$ matrices. The algebra structure is matrix multiplication, e is the identity matrix, t is the trace, and \det is the determinant (which is invariant under the larger group $\hat{G} = SL_n \times SL_n / \Delta\mu_n$ acting by $v \mapsto AvB^{-1}$).

Another algebra structure on V , with the same powers v^k , is given by the Jordan multiplication $A \circ B = \frac{1}{2}(AB + BA)$. This algebra is isomorphic to the Jordan algebra of Hermitian symmetric $n \times n$ matrices over the quadratic \mathbf{C} -algebra $\mathbf{C} + \mathbf{C}$, with involution $\overline{(z, w)} = (w, z)$.

The representation V has a similar Jordan algebra structure when $\hat{H} = PSp_{2n}$ and when $\hat{H} = F_4$. In the first case, V is the algebra of Hermitian symmetric $n \times n$ matrices over the complex quaternion algebra $M_2(\mathbf{C})$, and in the second V is the algebra of Hermitian symmetric 3×3 matrices over the complex octonion algebra.

When $\hat{H} = SO_{2n-1}$, the representation $V = \mathbf{C}e + V_0$ has a Jordan multiplication given by the quadratic form \langle, \rangle on V . We normalize this bilinear pairing to satisfy $\langle e, e \rangle = 2$, so $\det(v) = \frac{\langle v, v \rangle}{2}$ is the \hat{G} -invariant 2-form on V . The multiplication is defined, with e as identity, by giving the product of two vectors v, w in V_0 : $v \circ w = -\frac{1}{2}\langle v, w \rangle e$.

Finally, when $\hat{H} = G_2$, the representation V of dimension 8 has the structure of an octonion algebra, with $t(v) = v + \bar{v}$ and $\det(v) = v\bar{v}$. In all cases but this one \hat{G} is the connected subgroup of $GL(V)$ preserving \det , and \hat{H} is the subgroup of $GL(V)$ preserving all the forms $t(v^k)$ for $1 \leq k \leq \ell$. In the octonionic case, the subgroup $SO_8 \subset GL_8$ preserves \det , and the subgroup $SO_7 \subset SO_8$ preserves $t(v)$ and $t(v^2)$.

In general, $\det: V \rightarrow \mathbf{C}$ is a polynomial in the \hat{H} -invariants $t(v^k)$, given by the Newton formulae. The expression for $\ell! \cdot \det$ has integral coefficients; for example:

$$(11.6) \quad \begin{cases} 2 \det(v) = t(v)^2 - t(v^2) & \ell = 2 \\ 6 \det(v) = t(v)^3 - 3t(v^2)t(v) + 2t(v^3) & \ell = 3. \end{cases}$$

12. Representations of G lifted from H

We now describe the finite dimensional irreducible holomorphic representations π of G which are lifted from irreducible representations π' of H . This notion of lifting is due to Langlands: the parameter of π , which is a homomorphism $\varphi : \mathbf{C}^* \rightarrow \hat{G}$ up to conjugacy, should factor through a conjugate of \hat{H} .

We can parameterize the finite dimensional irreducible holomorphic representations π of G by their highest weights ω for B . The weight ω is a positive, integral combination of the fundamental weights ω_i of the simply-connected cover of G , so we may write (using the numeration of [B])

$$(12.1) \quad \omega = \sum_{i=1}^{\text{rank}(G)} b_i \omega_i \quad b_i \geq 0.$$

For ω to be a character of G , there are some congruences which must be satisfied by the coefficients b_i . (The group G is *not* simply connected, as its dual \hat{G} acts faithfully on the minuscule representation V .)

Since

$$(12.2) \quad \text{rank}(G) = \text{rank}(H) + (\ell - 1),$$

there are $(\ell - 1)$ linear conditions on the coefficients b_i which are necessary and sufficient for π to be lifted from π' of H . These conditions refine the congruences, and we tabulate them below.

Table 12.3

G	H	$\omega = \sum b_i \omega_i$ of G	ω lifted from H
SL_{2n}/μ_n	Spin_{2n+1}	$\sum_{i=1}^{n-1} i(b_i - b_{2n-i}) \equiv 0(n)$	$b_i = b_{2n-i}$ $1 \leq i \leq n-1$
SO_{2n}	Sp_{2n-2}	$b_{n-1} - b_n \equiv 0(2)$	$b_{n-1} = b_n$
E_6/μ_3	F_4	$(b_1 - b_6) + 2(b_2 - b_5) \equiv 0(3)$	$b_1 = b_6$ $b_2 = b_5$
Sp_6/μ_2	G_2	$b_1 - b_3 \equiv 0(2)$	$b_1 = b_3$
$SL_n \times SL'_n/\Delta\mu_n$	SL_n	$\sum_{i=1}^{n-1} i(b_i - b'_{n-1}) \equiv 0(n)$	$b_i = b'_{n-1}$ $1 \leq i \leq n-1$

When $G = SL_{2n}/\mu_n$, SO_{2n} , or Sp_6/μ_2 there are more classical descriptions of ω in the weight spaces \mathbf{R}^{2n} , \mathbf{R}^n , and \mathbf{R}^3 , respectively. We describe, in this language, which representations are lifted from H .

For $G = SL_{2n}/\mu_n$, a dominant weight ω is a vector $(a_1, a_2, \dots, a_{2n})$ in \mathbf{R}^{2n} with

$$a_1 \geq a_2 \geq \dots \geq a_{2n}$$

$$a_i \text{ in } 1/2 \mathbf{Z} \quad 1 \leq i \leq 2n$$

$$a_i \equiv a_j \pmod{\mathbf{Z}}$$

$$\sum a_i = 0.$$

The representations lifted from Spin_{2n+1} give dominant weights ω with

$$a_i + a_{2n+1-i} = 0 \quad 1 \leq i \leq n.$$

In particular: $a_n \geq 0 \geq a_{n+1}$, as $a_n + a_{n+1} = 0$.

For $G = SO_{2n}$, a dominant weight ω is a vector (a_1, \dots, a_n) in \mathbf{Z}^n with

$$a_1 \geq a_2 \geq \dots \geq a_{n-1} \geq |a_n|.$$

The representations lifted from Sp_{2n-2} satisfy $a_n = 0$.

Finally, for $G = Sp_6/\mu_2$, a dominant weight is given classically as a vector (a_1, a_2, a_3) in \mathbf{Z}^3 with $a_1 \geq a_2 \geq a_3 \geq 0$ and $a_1 \equiv a_2 + a_3 \pmod{2}$. The representations lifted from G_2 are those with $a_1 = a_2 + a_3$.

Define a connected, reductive subgroup L of G as follows.

$G = SL_{2n}/\mu_n$	$L = SL_n^2/\Delta\mu_n$	fixing a decomposition of the standard representation of $SL_{2n} : \mathbf{C}^{2n} = \mathbf{C}^n + \mathbf{C}^n$, and having determinant 1 on each factor
$G = SO_{2n}$	$L = SO_{n+1}$	fixing a non-degenerate subspace \mathbf{C}^{n-1} in the standard representation \mathbf{C}^{2n} .
$G = E_6/\mu_3$	$L = SL_6/\mu_3$	fixing the highest and lowest root spaces in the adjoint representation
$G = Sp_6/\mu_2$	$L = SL_2^3/\Delta\mu_2$	fixing a decomposition of the standard representation of $Sp_6 : \mathbf{C}^6 = \mathbf{C}^2 + \mathbf{C}^2 + \mathbf{C}^2$ into three non-degenerate, orthogonal subspaces
$G = SL_n^2/\Delta\mu_n$	$L = PGL_n$	fixing the identity matrix in the representation on $M_n(\mathbf{C})$

Proposition 12.4. *The finite dimensional irreducible representation π of G is lifted from H if and only if the space $\text{Hom}_L(\pi, \mathbf{C})$ of L -invariant linear forms on π is non-zero. In this case, the dimension of the space of L -invariant linear forms is given by the following table:*

Table 12.5

G	ω lifted from H	$\dim \text{Hom}_L(\pi, \mathbf{C})$
SL_{2n}/μ_n	$b_1(\omega_1 + \omega_{2n-1}) + b_2(\omega_2 + \omega_{2n-2}) + \cdots$ $\cdots + b_{n-1}(\omega_{n-1} + \omega_{n+1}) + b_n\omega_n$	$b_n + 1$
SO_{2n}	$b_1\omega_1 + b_2\omega_2 + \cdots + b_{n-2}\omega_{n-2} +$ $b_{n-1}(\omega_{n-1} + \omega_n)$	$\prod_{1 \leq i < j \leq n-2} \frac{b_1 + b_2 + \cdots + b_{j-1} + j - i}{j - i}$
E_6/μ_3	$b_1(\omega_1 + \omega_6) + b_3(\omega_3 + \omega_5) +$ $b_2\omega_2 + b_4\omega_4$	$\frac{(b_2+1)(b_4+1)(b_2+b_4+2)}{2}$
Sp_6/μ_2	$b_1(\omega_1 + \omega_3) + b_2\omega_2$	$b_2 + 1$
$SL_n^2/\Delta\mu_n$	$V \otimes V^*$	1

13. The proof of Proposition 12.4

The only easy case is when $G = SL_n^2/\Delta\mu_n$, so an irreducible π has the form $V \otimes V'$, where V and V' are irreducible representations of SL_n with inverse central characters. We have

$$\mathrm{Hom}_L(\pi, \mathbf{C}) = \mathrm{Hom}_{SL_n}(V \otimes V', \mathbf{C})$$

This space is non-zero if and only if $V' \simeq V^*$, when it has dimension 1 by Schur's lemma. These are exactly the π lifted from H .

When $G = Sp_6/\mu_2$ and $L = SL_2^3/\mu_2$, the space $\mathrm{Hom}_L(\pi, \mathbf{C})$ was considered in [G-S]. In the other cases, the subgroup L may be obtained as follows. Let $G_{\mathbf{R}}$ be the quasi-split inner form of G with non-trivial Galois action on the Dynkin diagram, and let $K_{\mathbf{R}}$ be a maximal compact subgroup of $G_{\mathbf{R}}$. We have



G	$G_{\mathbf{R}}$	$K_{\mathbf{R}}$
SL_{2n}/μ_n	$SU_{n,n}/\mu_n$	$S(U_n \times U_n)/\mu_n$
SO_{2n}	$SO_{n+1,n-1}$	$S(O_{n+1} \times O_{n-1})$
E_6/μ_3	${}^2E_{6,4}/\mu_3$	$(SU_2 \times SU_6/\mu_3)/\Delta\mu_2$

Note that in each case we have a homomorphism

$$L \hookrightarrow K = \text{complexification of } K_{\mathbf{R}}.$$

The image is a normal subgroup, and the connected component of the quotient is isomorphic to SO_2 , SO_{n-1} , and SO_3 , respectively.

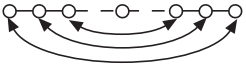
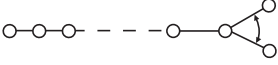
There is a real parabolic $P_{\mathbf{R}}$ in $G_{\mathbf{R}}$ associated to the fixed vertices of the Galois action on the Dynkin diagram. The derived subgroup of a Levi factor of $P_{\mathbf{R}}$ is given as follows.

$G_{\mathbf{R}}$	diagram	derived subgroup of Levi
$SU_{n,n}/\mu_n$		SL_2
$SO_{n+1,n-1}$		SL_{n-1}
E_6/μ_3		SL_3

Let $B_{\mathbf{R}}$ be the Borel subgroup of $G_{\mathbf{R}}$ contained in $P_{\mathbf{R}}$, and let $T_{\mathbf{R}}$ be a Levi factor of $B_{\mathbf{R}}$.

In the Cartan-Helgason theorem, one uses the Cartan decomposition $G_{\mathbf{R}} = K_{\mathbf{R}} \cdot B_{\mathbf{R}}$ to show that K has an open orbit on the complex flag variety G/B , with stabilizer the subgroup T^θ of T fixed by the Cartan involution. The representations π of G with $\text{Hom}_K(\pi, \mathbf{C}) \neq 0$ are those whose highest weight χ is trivial on T^θ , in which case $\text{Hom}_K(\pi, \mathbf{C})$ has dimension 1. This is proved in [G-W, 12.3], where the subgroup T^θ is also calculated.

Similarly, one shows that the subgroup L of K has an open orbit on the flag variety G/P , with stabilizer the connected component $(T^\theta)^0$ of T^θ , which is a torus. The representations π of G with $\text{Hom}_L(\pi, \mathbf{C}) \neq 0$ are those whose highest weight χ is trivial on $(T^\theta)^0$. These one finds, after a brief calculation, are those lifted from H . The space $\text{Hom}_L(\pi, \mathbf{C})$ is isomorphic, as a representation of K/L , to the irreducible representation of the Levi factor of P which has highest weight χ . This completes the proof.

14. The real form of L

We now descend the subgroup $L \rightarrow G$ defined before Proposition 12.4 to a subgroup $L_0 \rightarrow G_0$ over \mathbf{R} , by using minuscule co-weights. Let S be a maximal torus in L , and let $\lambda : \mathbf{G}_m \rightarrow T$ be a minuscule co-weight which occurs in the representation V of \hat{G} .

Proposition 14.1. *There is an inclusion $\alpha : L \rightarrow G$ mapping S into T , and a minuscule co-weight $\mu : \mathbf{G}_m \rightarrow S$ of L , such that the following diagram commutes*

$$\begin{array}{ccccc} \mathbf{G}_m & \xrightarrow{\mu} & S & \rightarrow & L \\ & & \downarrow \alpha & & \downarrow \alpha \\ \mathbf{G}_m & \xrightarrow{\lambda} & T & \rightarrow & G \end{array}$$

Proof. If $\alpha_0 : L \rightarrow G$ is any inclusion the image of S is contained in a maximal torus T_0 of G . Since T and T_0 are conjugate, we may conjugate α_0 to an inclusion $\alpha : L \rightarrow G$ mapping S into T .

The co-character group $X_\bullet(S)$ then injects into $X_\bullet(T)$. To finish the proof, we must identify the image, and show that it intersects the W -orbit of λ in a single W_L -orbit of minuscule co-weights for L . We check this case by case. For example, if $G = E_6/\mu_3$ and $L = SL_6/\mu_3$, the group $X_\bullet(T)$ is the dual E_6^\vee of the E_6 -root lattice, and $X_\bullet(S)$ is the subgroup orthogonal to a root β . One checks, using the tables in Bourbaki [B], that precisely 15 of the 27 elements in the orbit $W\lambda$ are orthogonal to each β , and that these give a single $W_\beta = W_{SL_6}$ orbit.

In each case, we tabulate the dimension of T/S , and the size of the W_L -orbit $W\lambda \cap X_\bullet(S) = W_L\mu$

Table 14.2

G	L	$\dim(T/S)$	$\#W\lambda$	$\#W_L\mu$
SL_{2n}/μ_n	SL_n^2/μ_n	1	$2n^2 - n$	n^2
SO_{2n}	SO_{n+1}	$\frac{n+1}{2}$ n odd $\frac{n}{2}$ n even	$2n$	$n+1$ n odd n n even
E_6/μ_3	SL_6/μ_3	1	27	15
Sp_6/μ_2	SL_2^3/μ_2	0	8	8
SL_n^2/μ_n	PGL_n	$n-1$	n^2	n

Corollary 14.3. *If L_0 is the real form of L with Cartan involution $\theta = \text{ad } \mu(-1)$, then L_0 embeds as a subgroup of G_0 over \mathbf{R} . The symmetric space $\mathcal{D}_L = L_0(\mathbf{R})/K_{L_0}$ has an invariant complex structure, and embeds analytically into \mathcal{D} . Moreover,*

$$\dim_{\mathbf{C}} \mathcal{D}_L = \frac{1}{2} \dim_{\mathbf{C}} \mathcal{D}.$$

The last inequality is checked, case by case. We tabulate G_0 , L_0 , $\dim \mathcal{D}$, and $\dim \mathcal{D}_L$ below

Table 14.4

G_0	L_0	$\dim \mathcal{D}$	$\dim \mathcal{D}_L$
$SU_{2,2n-2}/\mu_n$	$SU_{1,n-1}^2/\mu_n$	$4n-4$	$2n-2$
$SO_{2,2n-2}$	$SO_{2,n-1}$	$2n-2$	$n-1$
${}^2E_{6,2}/\mu_3$	$SU_{2,4}/\mu_3$	16	8
Sp_6/μ_2	SL_2^3/μ_2	6	3
$SU_{1,n-1}^2/\mu_m$	$PU_{1,n-1}$	$2n-2$	$n-1$

Since $\dim \mathcal{D}_L = \frac{1}{2} \dim \mathcal{D}$, this suggests the following problem. Let $G_{\mathbf{Q}}$ and $L_{\mathbf{Q}}$ be descents of G_0 and L_0 to \mathbf{Q} , with $L_{\mathbf{Q}} \hookrightarrow G_{\mathbf{Q}}$. This gives a morphism of Shimura varieties

$$S_L \rightarrow S_G$$

over \mathbf{C} , with $\dim(S_L) = \frac{1}{2} \dim S_G$. The algebraic cycles corresponding to S_L contribute to the middle cohomology $H^{\dim S_G}(S_G, \mathbf{C})$. Can these Hodge classes detect the automorphic forms lifted from H ?

15. The group \hat{G} in a Levi factor

Recall that the center μ_ℓ of \hat{G} is cyclic. Let

$$(15.1) \quad \hat{J} = \mathbf{G}_m \times \hat{G}/\Delta\mu_\ell,$$

which is a group with connected center. We first observe that \hat{J} is a Levi factor in a maximal parabolic subgroup \hat{P} of a simple group of adjoint type \hat{M} . The minuscule representation V occurs as the action of \hat{J} on the abelianization of the unipotent radical \hat{U} of \hat{P} .

Recall that the maximal parabolic subgroups \hat{P} of \hat{M} are indexed, up to conjugacy, by the simple roots α . We tabulate \hat{M} , the simple root α corresponding to \hat{P} , and the representation $\hat{U}^{ab} = V$ below.

Table 15.2

\hat{G}	\hat{M}	α of \hat{P}	$V = U^{ab}$
SL_{2n}/μ_2	PSO_{4n}	α_{2n}	$\bigwedge^2 \mathbf{C}^{2n}$
SO_{2n}	PSO_{2n+2}	α_1	\mathbf{C}^{2n}
E_6	E_7	α_7	\mathbf{C}^{27}
Spin_7	F_4	α_4	\mathbf{C}^8
SL_n^2/μ_n	PGL_{2n}	α_n	$\mathbf{C}^n \otimes \mathbf{C}^n$

Proposition 15.3. *The centralizer of \hat{H} in \hat{M} is SO_3 , and $\hat{H} \times SO_3$ is a dual reductive pair in \hat{M} .*

This is checked case by case, and we list the pairs obtained below.

$$SO_3 \times PSp_{2n} \subset PSO_{4n}.$$

$$SO_3 \times SO_{2n-1} \subset PSO_{2n+2}$$

$$SO_3 \times F_4 \subset E_7$$

$$SO_3 \times G_2 \subset F_4$$

$$SO_3 \times PGL_n \subset PGL_{2n}.$$

16. Bibliography

- [A] Jim Arthur, Unipotent automorphic representations: conjectures. In: Astérisque 171–172 (1989), 13–71.
- [B] N. Bourbaki, Groupes et algèbres de Lie. Hermann, Paris, 1982.
- [D] Pierre Deligne, Variétés de Shimura: Interpretation modulaire. In: Proc. Symp. Pure Math **33** (1979), part 2, 247–290.
- [dS] J. de Siebenthal, Sur certains sous-groupes de rang un des groupes de Lie clos. Comptes Rendus **230** (1950), 910–912.
- [D-K] J. Dadok and V.G. Kac, Polar representations. J. Algebra **92** (1985) 504–524.
- [G-W] Roe Goodman and Nolan Wallach, Representations and invariants of the classical groups. Cambridge, 1998.
- [G] Benedict Gross, On the motive of G and the principal homomorphism $\mathrm{SL}_2 \rightarrow \hat{G}$. Asian J. Math. **1** (1997), 208–213
- [G-S] Benedict Gross and Gordan Savin, Motives with Galois group of type G_2 : An exceptional theta correspondence, Compositio Math. **114** (1998), 153–217.
- [H] Jim Humphreys, Reflection groups and Coxeter groups. Cambridge Studies **29**, 1990.
- [K] V.G. Kac, Some remarks on nilpotent orbits. J. Algebra **64** (1980), 190–213.
- [S-K] M. Sato and T. Kimura, A classification of irreducible prehomogeneous spaces and their relative invariants. Nagoya Math. J. **65** (1977), 1–55.
- [V-Z] David Vogan and Gregg Zuckerman, Unitary representations with non-zero cohomology. Compositio Math. **53** (1984), 51–90.